

KELLY COMMUNIQUE

VOLUME EIGHT

DECEMBER 1990



ENSIGN JENNY HANSEN
ZIPPING UP THE NEXT GENERATION
FOR GENE RODDENBERRY

LOG ENTRY

CAPTAIN'S LOG STARDATE 44395.2:

WE HAVE DIVERTED TO STARBASE XANTHOR III, THE COMMAND BASE IN THIS SECTOR, TO TRANSFER THE SURVIVORS OF THE ATTACKED STARLINER. AS I HAD FEARED, THE ROMULAN STAR EMPIRE HAD OFFICIALLY DECLARED WAR WITH THE FEDERATION, WITH ATTACKS ON ROMULAN OUTPOSTS AND THE DESTRUCTION OF ROMULAN VESSELS AS PROVOCATION. IT COULDN'T HAVE COME AT A WORSE TIME. THE RECENT ENCOUNTER WITH THE BORGS HAS LEFT STARFLEETS FORCES GREATLY REDUCED. IT HAD SHIFTED THE BALANCE OF POWER AND WE WOULD BE SERIOUSLY OUTNUMBERED IN ANY CONFLICT WITH THE ROMULANS. ALL KELLY CLASS DREADNOUGHTS HAVE BEEN CALLED INTO ACTION, INCLUDING THE NEWLY COMPLETED STARSHIP THE U.S.S. AMY NCC-3403, HEADING DIRECTLY FROM THE SHIP YARDS. THE STARBASE COMMANDER, COMMADORE TREBOR N. CEENOGE, IS A LONG TIME PERSONAL FRIEND OF MINE. DURING MY MISSION BRIEFING I WAS SHOCKED AT HIS RUDE BEHAVIOR TOWARDS ME. HE SEEMED TO BE VERY ANGRY WITH ME. I WONDERED IF I HAD DONE SOMETHING TO OFFEND HIM BUT I COULDN'T

THINK OF WHAT IT MIGHT BE. WHEN I ASKED HIM A ABOUT IT, HE SNAPPED AT ME, REMINDING ME OF HIS HIGHER RANK. HE TOLD ME THAT I NEEDED TO CONCERN MYSELF WITH OBEYING ORDERS AND NOT OUR SUPPOSED FRIENDSHIP. I COULDN'T UNDERSTAND THAT KIND OF TREATMENT FROM A FRIEND I HAD GROWN UP WITH AND LOVED LIKE A BROTHER. AS I THOUGHT OF ALL THE LIFE THAT WOULD BE LOST IN ANOTHER WAR, I WONDERED IF THERE WAS SOME WAY TO PREVENT IT.

CAPTAIN'S PERSONAL LOG:

ON OCTOBER 27th OUR CREW ENJOYED SOME SHORE LEAVE ATTENDING A HALLOWEEN PARTY WITH DAVE POWELL. I WOULD PERSONALLY LIKE TO THANK HIM FOR HIS INVITATION, A GOOD TIME WAS HAD BY ALL, AND I HOPE TO RETURN HIS HOSPITALITY IN THE NEAR FUTURE.

CAPTAIN DENNIS R. HOLLINGER
U.S.S. KELLY NCC-3400

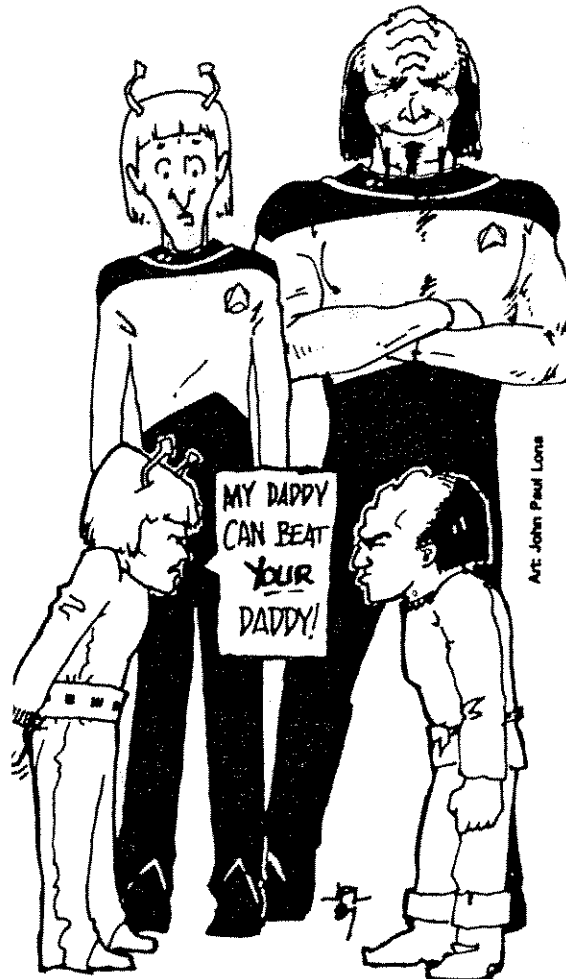

ASK NUMBER ONE

Ensign Jenny Hansen asks about alien encounters and how she can find out more about them???

As members of a Star Trek fan club, we are a part of an ever growing group of people who believe that we are not alone in the universe. After all, it is the height of conceit to think that we humans are the only intelligent life forms out here. With the vast number of UFO sightings and ever increasing evidence, it is almost irrefutable that extra-terrestrials have, and still do, visit the earth.

Almost every day, we hear of people experiencing alien contact, from the man who witnessed bizarre alien rituals to the woman claiming to have been impregnated by visitors from space. As far-fetched as some of these encounters seem, it is difficult to dismiss all sightings and contacts as hoaxes. It is up to the individual, however, to decide which stories and accounts he or she wishes to believe.

Alien encounters have been immortalized through the mediums of television, major motion pictures, and best selling novels. Television has produced such notable programs as Star Trek, The Invaders, My Favorite Martian, Alien Nation, and War of the Worlds. Block-buster movies like E.T., Predator, Alien, Close Encounters of the Third Kind, Moontrap, and many others draw record crowds to see yet another new Alien. Science fiction novels are widely read throughout the world. The human race as a whole seems to have an insatiable curiosity about alien life forms. To borrow a term from Mister Spock, we find them "fascinating."

We can't forget the Halloween night when they broadcast the "War of the Worlds" program over the radio. There was mass hysteria and panic because people really believed that we were being invaded by Martians.

Our society, at this point in time, is primed and ready for the big alien encounter, maybe a little too ready. It is doubtful that the visiting delegations from a foreign world would survive first contact with our alien hungry population. They would be better off observing us from a distance and listening to our messages of peace that we send out into space, biding their time until we are ready to receive them.

Those who are interested in knowing more about alien encounters should try reading magazine articles in legitimate magazines such as "Life," "Time," or a science magazine like "Omni," or "Science Digest." You may also wish to check out "Time Life Books'" entries on aliens and strange encounters. Best-selling author Whitley Streiber has written a book called "Communion" which he claims is based on his true-life experiences with alien visitors. Other than that, we will have to wait until some one does an in-depth interview with an alien to find out more. If you have other questions about anything...ASK NUMBER ONE!

KELLY COMMUNIQUE:

COUNSELOR'S LOG

By RHONDA HOLLINGER

MEMORIES OF THE LAST YEAR

During the past year the U.S.S.KELLY has reached out to broaden her adventures. We as her gallant crew are proud of the accomplishments we have made. The KELLY name is becoming well known among the Star Trek world. The California Convention Mission was one of the most outstanding in the ship's history.

The crew is now eagerly working on their knowledge and communication skills for rank advancement.. Knowledge skills is an important part of the group. Crew members are taking turns at putting together a bi-monthly Communique. This has been a great assignment for the crew member who has dared to take the challenge. Also, each member of the crew is continually recruiting new members. Some of the activities we like to engage in is Trivia Contests, letter writing, etc. Most of all we like to get together to help each other on special assignments and projects.

We are excited for some upcoming activities and events. We have planned some away missions to visit other Star Ship's and their groups. One of our main goals is to reach out to other people to get to know them. Star Trek is something we have in common, and we want to build on that common relationship.

There are so many exciting things going on at this time in our Salt Lake area. We want to get involved and want to get other people involved. We have a CONduit convention coming up in April 1991. Mr. Dave Powell has been our contact for this convention. Also we have been in contact with Mr. Bill Sargent. He is a STAR TREK character from the episode Conscience of the King. He owns a playhouse in the Salt Lake area. He has invited us out to a play and to meet with him. There is much much more so keep in contact so you won't to be left out.

CREW COMPLEMENT

Jennifer Sweeney and Sandy Williams have joined the crew of the U.S.S. Kelly. WELCOME ABOARD!

STARGAZER



THE OFFICERS AND CREW OF THE U.S.S. KELLY
WOULD LIKE TO GIVE SPECIAL THANKS
TO
STAR TREK'S
"REAL McCOY"

"The Big Bird's Dream"
by DeForest Kelley

Dedicated to all whose hearts follow Star Trek

A long time ago, in a galaxy far, far away,
There lived a big bird nesting on a play.
He thought if he could hatch it and get it on the air,
He'd make himself a fortune and build himself a lair.

The day finally came and the story was born.
He let out a cackle: "No more corn!"
He flew from his nest with the play in his claw,
Certain to sell it, for it had no flaw.

The story he hatched within this yarn
Took place on a ship as big as a barn.
Not only that, it was in outer space,
Far removed from the human race.

Its crew searched the universe for worlds unknown
To teach and learn--and not try to own.
Not only that, they built a new nation
This time known as The Federation.

All of this, taking place in the skies
On a starship known as The Enterprise.
Now wouldn't you think, with a plot like this,
The big bird had what couldn't miss?

Well, he landed in Burbank on Hollywood Way,
And headed east, to sell his play.
Things weren't as easy as he thought they'd be--
Particularly when dealing with NBC.

The Enterprise crew was one of a kind,
Superb in their work, with good things in mind.
Different in color and different in race,
Green, white, yell and token black face.

At first, the black was not to be,
'Til the big bird screamed at NBC:
"It;s either she or I" he began to yell,
"Who knows who's gonna ring whose bell?"

With great reluctance they agreed to say:
"Okay, fellows, we'll do it his way."
At a later time, on another day,
They'd be the first to boast they went that way.

Most who read it said: "This bird is nuts!"
But there was one among them possessed with guts.
"Let's go with this bird, loud and clear--
He's saying things people should hear."

"Let's give it a try and hope it will work."
So spoke the head of the big network..
So the pilot was made and they all took a look--
"My God!" one shouted, "he's filmed a book!"
Another one yelled, "It's too far out!
I don't understand what it's all about!"
But the one with guts had a grin on his face
Now he was ready to state his case.

"Far out?" he said, "I liked what I heard,
And I'm still gonna go with this crazy bird."
So they made another pilot--with a change here and there,
And finally, they got it on the air.

The big bird felt a sense of elation
After so many days of complete frustration.
But now he knew the big job was done
And he was proud of his fine new son.

One thing was left for the big bird to do:
Find a name for his dream-come-true.
He gave a big party so the brass would appear,
To name this dream he held so dear.

When the party calmed down and the feeling was mellow,
The bird stepped forward to christen this fellow.
"Lift your glasses," he said out loud,
"I've got a new baby of which I'm proud!"

He took an idic from his hand,
The symbol he'd created for the change in man.
He placed it tenderly around the small neck
And, in a mellifluous voice, said: "Star Trek"

The brass with guts jumped up and down--
"My God!" he said, "what a sound!
How did he think of such a name?
It's commercial as hell--the name of the game!"

Well, the public loved it--but the Neilson was low
And they tell the networks what to show.
The word was out for all to hear:
Star Trek dead--after second year.

The rest is history, as you surely know,
For you, the fans, saved the show.
The millions of letters you sent to the brass
Simply knocked them on their ass!

But after one more year they put it away,
Not knowing it would rise in syndicated play.
Then came conventions--and letters--and toys,
Re-runs and ratings and lots of noise.

Finally the studio was heard to say:
"We'll remake Star Trek another way."
"How will we do it?" one of them said,
"Not as a series, the re-runs aren't dead."
"let's do it as a movie, a special, or a play--
For heaven's sake, let's do it some way!
Precious moments are flying by--
The actors are aging and soon may die."

"Are they still available--or should we re-cast?
Without the originals, how long would it last?
Go get the big bird--he knows where they are
And have him remind Spock he's still not a star."

"We've got to keep their egos down
In case replacements can't be found."
So in flew the big bird, ready to squeal.
Naturally anxious to make a deal.

"First," he said, "we should discuss the star--
For all of them probably think they are!"
"Don't be funny," an executive said,
"If that's the case, the whole thing's dead."

"What's with Shatner? How does he look?"
"I don't know--but he's written a book.
Seems he wanted the world to know
How he suffered, making that show."

"What's with Kelley--what's with his life?"
"He's living in the Valley--with the very same wife!
I know one thing that's buggin' him,
He's sick of that line: He's dead, Jim!"

How about Doohan, the one with the brogue,"
"Well, he bought a motor-coach and hit the road.
He's grown a beard--it's silver and black,
And he says he wants to keep it, if he comes back."

"What about Takei--he flew the damned ship..."
"Well, he's into politics--a whole new trip.
He had a job on the Mayor's staff,
But they couldn't take that crazy laugh!"

"Okay, okay, what about Nichelle?
The one you said would ring our bell?"
"She's working for NASA--goes all over the nation
Trying to interest women in the space administration.

"They're using the Enterprise to colonize space
And can't seem to do it without the female race.
She says she's had it in Communications
And wants to come back in Public Relations."

"Well, where the hell's Koenig--our young Russian Lad?"
"Oh, he's writing for films--and he's really not bad.
As a matter of fact, if he can be found,
He could be the one to get this off the ground!"
"That just about covers the entire crew....
Majel's no problem--she's married to you!"
"Don't you believe it, not on your life!
I don't make deals with my very own wife."

"And even though she's married to me,
She still commands the same high fee.
And if this show goes, she'll be back, you can bet--
I've never written a script without her yet.

"And there's one more actor you've left out
That I really think we should talk about.
I know it's something you hate to discuss
Because it's going to create quite a fuss.

"I'm referring to Nimoy and what he has to say.
He's in New York, doing a play.
He's portraying a doctor and says it's a joy--
And he might come back if he could play McCoy."

"McCoy's role?" the executive said,
"My God, man, he's out of his head!
Well, I'm telling you, that really takes guts--
The brass will think we've all gone nuts!"

"What about Kelley, if Spock plays McCoy?
He'll just flip if we get another boy."
The big bird spoke with that smile on his face,
The one he wears when he's solved a case.

]
"Easy, gentlemen, can't worry about that....
I can fix him in nothing flat.
So just relax and calm your fears....
I'll paint De green--and give him the ears!"

So that brings us up to where we are today,
With thousands of people gathered to say
"Star Trek Lives!"--it will not die--
When will someone make it fly?

DATA BANKS

EXTRACTED FROM READERS' DIGEST
BY LT. WAYNE SWENSON

Ever Wonder Why...

...manholes are always round?
If they were any other shape—rectangular, oval, triangular—the manhole cover could be turned so that it would fall through the hole. ...that painful spot on the elbow is called the "funny bone"?

It's actually a nerve that runs close to the surface at the tip of the elbow. But it was once thought that this unmistakable pain was caused by striking the upper arm bone, the humerus—hence the "humorous" or "funny" bone.

...coin banks are pig-shaped?
Cookware in Europe was once made of a dense, orange clay called pygg. As housewives began saving coins in jars made of this clay, the jars became known as pygg pots. In the 19th century, English potters misunderstood the term, and when asked to make a pygg bank, they made one shaped like a pig.



...so many barns are painted red?
In the mid-19th century, some American farmers found they could make a cheap and long-lasting wood covering from red iron oxide, skim milk, lime and linseed oil. This mixture gave the barn a bright-red color. Its use became so widespread that, by the late 1800s, red had become traditional for barns.

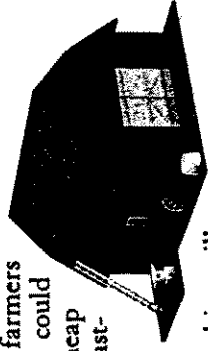

...aluminum foil is shiny on one side and dull on the other?
To make the foil, a block of aluminum is flattened into two sheets and then passed between two highly polished rollers, two sheets at a time, one on top of the other. The sides of the sheets that come into contact with the rollers get a high shine; the two inner sides come out dull. (Contrary to popular belief, it makes no difference which side gets placed next to the food.)

...a mile is exactly 5280 feet?
In ancient Rome, there was a unit of land measure called *mille passuum*, Latin for "a thousand paces." Since one pace was considered to be five feet, *mille passuum*, later simply *milia*, equaled 5000 feet.

Great Britain, once a part of the Roman empire, used *milia* and further abbreviated the word to "mile." But the British also used the furlong—a measure of 625 feet, the approximate length of a typical plowed furrow—while surveying.

When the foot was standardized in the late 17th century, the furlong became 660 feet, and the mile, which had always equaled eight furlongs, became 5280 feet. ...circus acts are performed in rings?

Philip Astley, widely considered to have founded the modern circus in the late 18th century, noticed that his trick riders could stay in the saddle better when the horses moved in a tight circle. Rings were put down to guide the horses.

...that delicious dessert is called an ice cream "sundae"?

A popular explanation is that in the late 1800s, local laws forbade the sale of soda on the Sabbath. To attract the Sunday crowd, ice cream parlors started serving sodas with ice cream and fruit concoctions, which people began calling "sundays." Later the parlors altered the word's spelling, hoping to change the dish's image to that of an everyday treat.

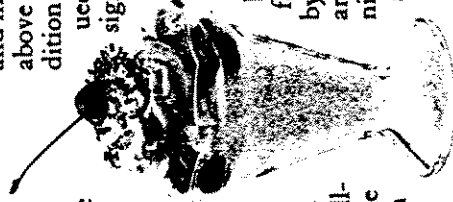

...the stripes on men's ties almost always slant downward and toward the wearer's left?

The reason is largely practical: the four-in-hand knot forces the cloth through tremendous contortions, and cutting the material diagonally across the weave makes the tie more supple. Since the fabric is cut uniformly, the stripes always fall in the same direction.

...riders almost always mount their horses from the left?

Centuries ago, most men carried swords on the left hip, which was easily accessible to the right hand. With a long sword dangling from a rider's left hip, it was easier to mount a horse by putting one's left foot into the stirrup and throwing one's right leg across the horse's back.

...flags fly at half-mast when someone dies?

After a naval battle, it used to be custom for the defeated ship to lower its flag to signal surrender and make room for the victor's flag above it. Apparently, after this tradition faded, a lowered flag continued to be used as a universal sign of respect.

...golf balls have dimples?

Golf balls used to be smooth as an egg, until someone noticed that scarred balls seemed to travel a lot farther. Dimples give extra lift by creating a high-pressure area on the underside of a spinning ball and a low-pressure area above. This lift keeps the ball in the air longer, allowing it to travel farther.

...X's at the end of a letter signify kisses?

In the Middle Ages, illiterate people often signed documents by making an X. This X, or cross, signified a sacred oath to fulfill the obligations specified in the document. Signers then kissed the X to affirm their sincerity. Eventually the X and the kiss became synonymous.

SIZE COMPARISON CHART

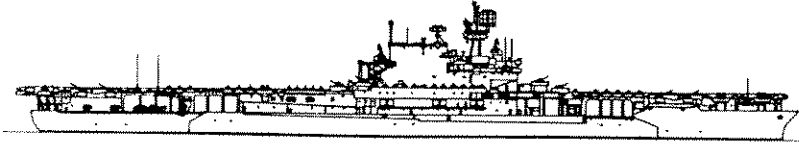

ENTERPRISE CV-6
YORKTOWN CLASS AIRCRAFT CARRIER

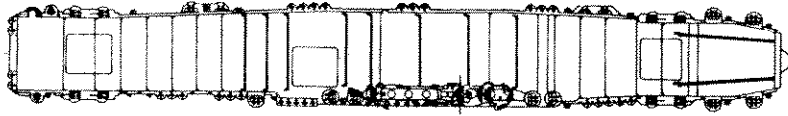

submitted by
CAPT. DENNIS R. HOLLINGER

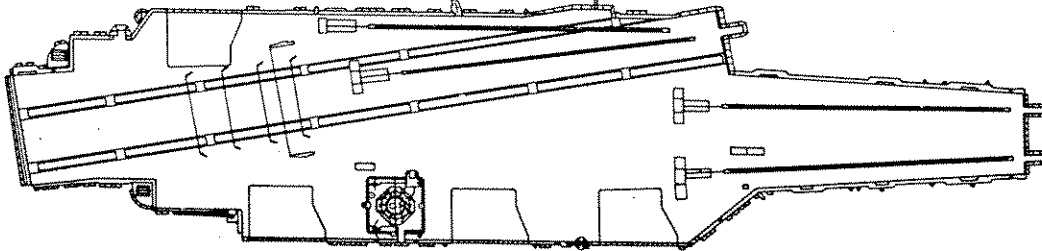
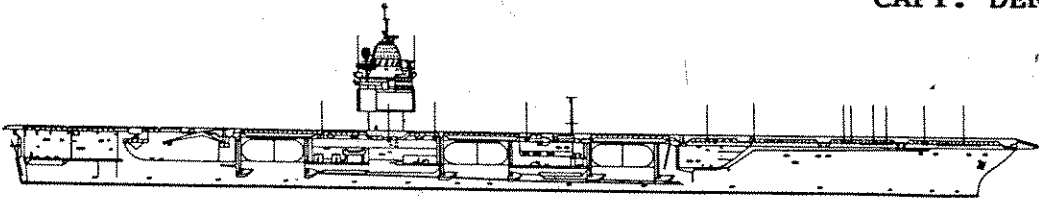

ENTERPRISE CVN-65
NUCLEAR-POWERED AIRCRAFT CARRIER

CONSTITUTION CLASS
U.S.S. ENTERPRISE NCC-1701

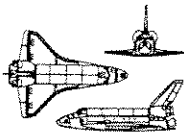

SPACE SHUTTLE
ENTERPRISE OV-101

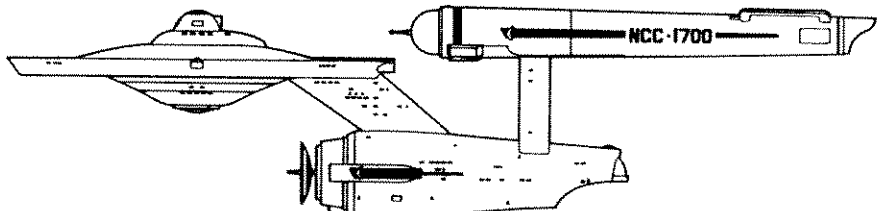
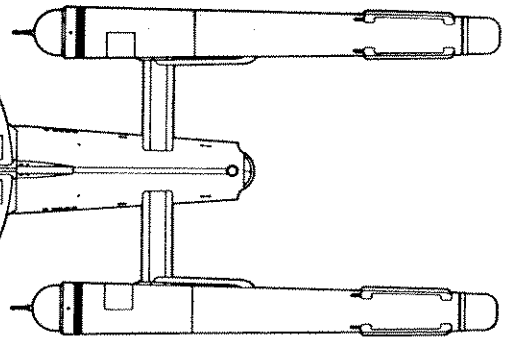
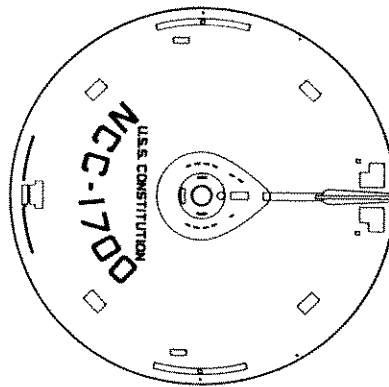

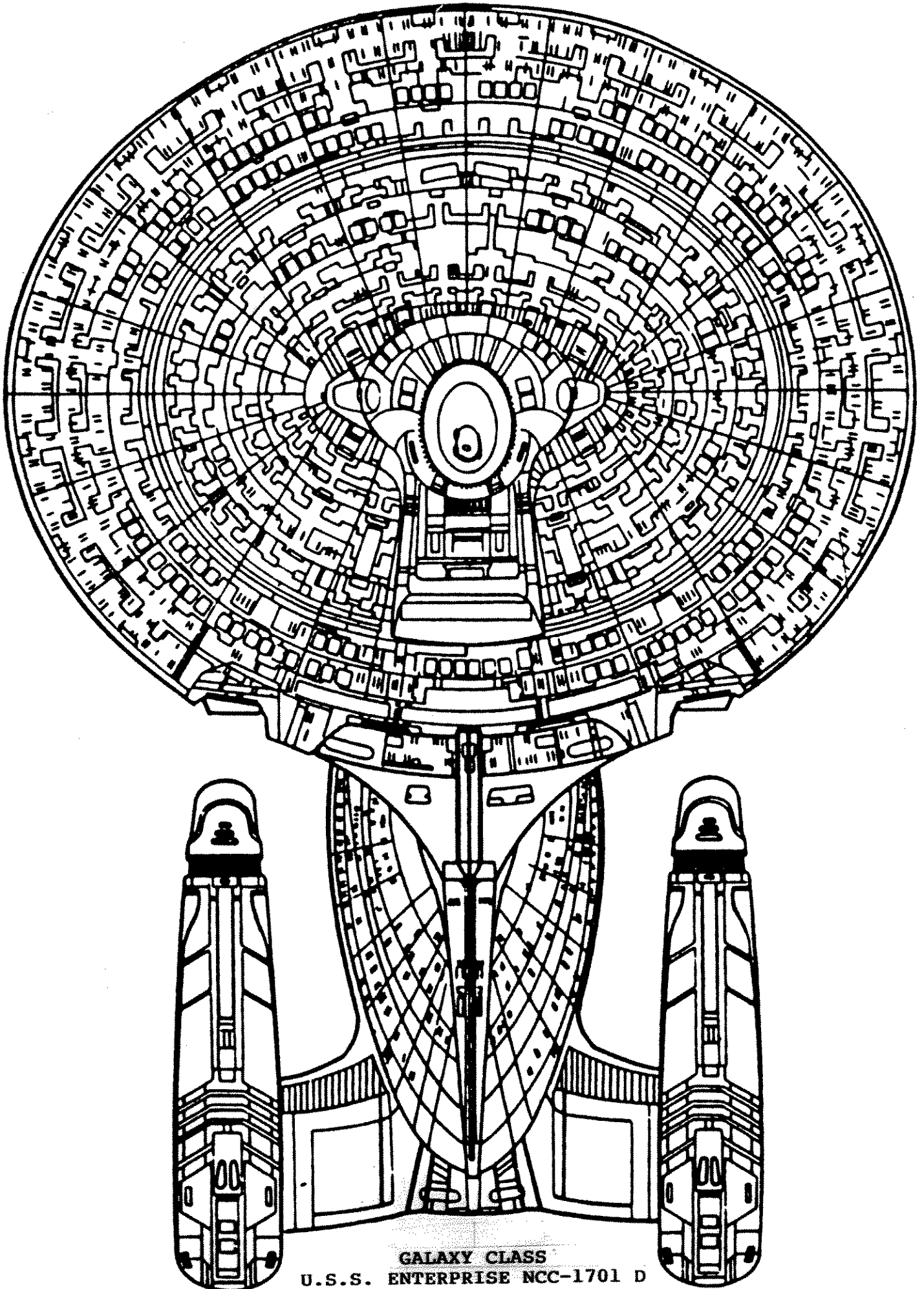

GALAXY CLASS
U.S.S. ENTERPRISE NCC-1701 D

CALENDAR OF EVENTS

DECEMBER 1990

SUNDAY	MONDAY	TUESDAY	WEDNESDAY	THURSDAY	FRIDAY	SATURDAY
30	31					1 KELLY ACTIVITY NIGHT (RED HOUR) LETTER WRITING
2	3	4	5	6	7	8 SEE MOVIE "THREE MEN AND A LITTLE LADY"
9 MICHAEL DORN'S (LT. WOLF) BIRTHDAY	10	11	12	13	14	15 CHRISTENING OF THE U.S.S. FAHRION NCC-2510
16	17	18 SENIOR OFFICER'S MEETING	19	20	21	22
23	24	25 CHRISTMAS	26	27	28	29 NICHELLE NICHOLS'S (LT. UHURA) BIRTHDAY HOLIDAY PARTY

CALENDAR OF EVENTS

JANUARY 1991

SUNDAY	MONDAY	TUESDAY	WEDNESDAY	THURSDAY	FRIDAY	SATURDAY
		1	2	3	4	5
	7	8	9	10	11	12
	14	15	16	17	18	19
	21	22	23	24	25	26
	28	29	30	31		
	6					
	13					
	20					
	27					

KELLY
ACTIVITY NIGHT
(RED HOUR)

SENIOR
OFFICER'S
MEETING

LT. COMMANDER
NADA HENLINE'S
BIRTHDAY

DeFOREST KELLEY'S
(DR. MCCOY)
BIRTHDAY

November 11, 1990

An away team consisting of four members of the U.S.S. Kelly undertook a special assignment. The team included Lt. Mark Griffeth, Ensign Cynthia Claytor, Ambassador Deena Griffeth, and Cadet Tommy Claytor.

At approximately 2:00 p.m. we beamed into the Crossroads Mall. Our mission was to obtain signatures on a petition for a U.S. Postal Stamp honoring Star Trek's U.S.S. Enterprise and the Space Shuttle Enterprise. Being in uniform caused a great deal of curiosity which allowed us to speak to a lot of people, mostly because they were delighted to see such devoted people like us. Some of them even wanted to join our group, such as Tristie Christensen and her father Jay, Michael Eaquikta, Robert Zoque, Amy Rohling, Leonard Evans, Michelle Wolcott, Sue Wall, and Michael. Others had little time to talk but they signed the petition and gave their verbal support. We saw and heard many interesting things but I guess the most interesting was when we stopped in a shop called The Rare Earth. There we met Deanna Thompson, a Trekker, who had something to show us. She had a rock formation that looked like the planet killer in the episode The Doomsday Machine. Most customers did not appreciate this but she knew we would; and we did. It was amazing how much it did look like the Doomsday Machine. It was beautiful and worth looking at. As we were leaving the mall one of the last people we talked to in a jewelry shop asked us to beam him out in a half hour.

All and all we had a very successful day and got 38 signatures on our petition; and we are not done yet!

Ensign Cynthia Claytor

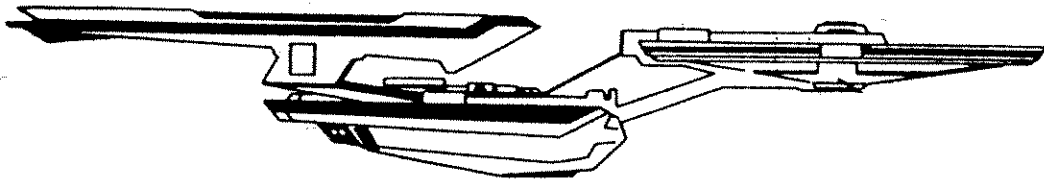

BRIAN PIMENTA'S UPGRADING OF
THE CONSTITUTION CLASS,
ENTERPRISE NCX-2701

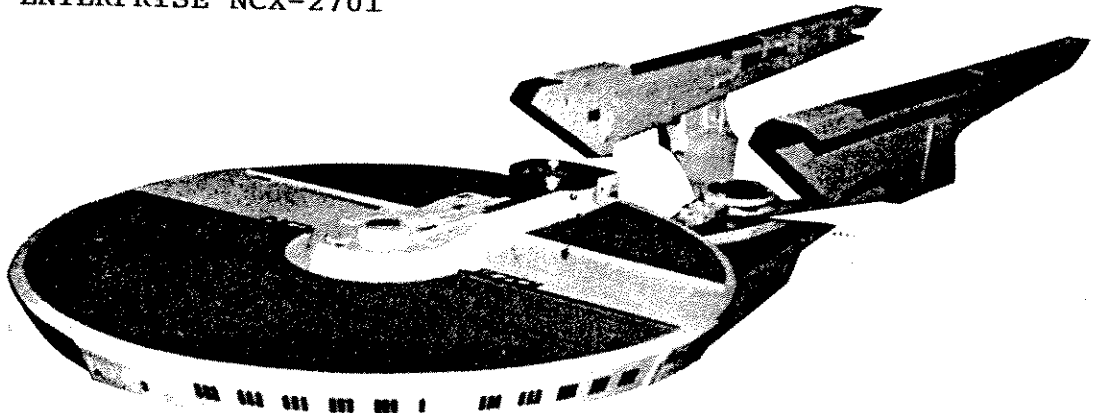

ZIPPER ART

BY JENNY HANSEN

THE ZIPPER ART WAS ORIGINALLY STARTED IN ARIZONA. MY NEIGHBORS BROUGHT THE IDEA TO UTAH LAST SPRING. ZIPPER ART IS DONE BY CUTTING THE FABRIC OFF OF THE ZIPPER AND GLUING THE ZIPPER TO MAKE THE DESIGN. WHEN THE ZIPPER DRIES, YOU THEN GLUE COLORED SAND BETWEEN THE ZIPPER. YOU THEN TEAR THE WAXED PAPER OFF. TAKE THE PICTURE AND GLUE IT TO A PIECE OF NAUGAHYDE AND FRAME IT. (FOR MORE DETAILS ON HOW TO MAKE THE ZIPPER ART, CONTACT JENNY HANSEN AT 968-0421.)

I CREATED MY OWN DESIGN. IT TOOK ME APPROXIMATELY THREE WEEKS. I WAS NERVOUS BECAUSE OF THE AMOUNT OF TIME IT TOOK. I WAS VERY CAREFUL IN PICKING OUT THE FRAME BECAUSE IT WAS TO BE GIVEN TO A VERY SPECIAL PERSON--GENE RODDENBERRY. BEING ON STAGE MADE ME NERVOUS AND I COULDN'T TALK VERY LOUDLY.

P.S. TO GENE RODDENBERRY:
I'M SORRY I DIDN'T TALK VERY LOUD WHEN I WAS ON STAGE WITH YOU. I HOPE THAT YOU AND MAJEL LIKE MY CREATION. PLEASE WRITE TO ME. I'M SENDING AN SASE WITH THE COMMUNIQUE.

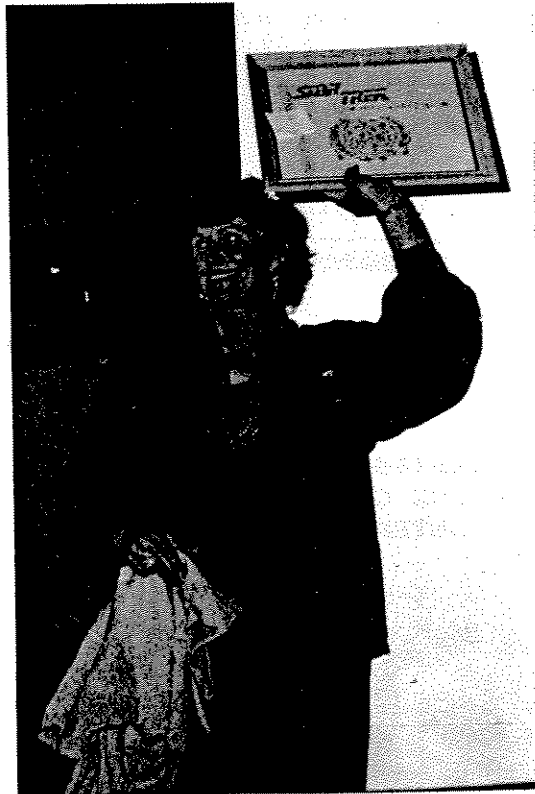



EXCERPT FROM
"A CURRENT AFFAIR"



DEPARTMENT OF ENGINEERING

DREAM LAND

In Nevada there is reported a mysterious town, isolated in a Nevada Test Site, surrounded by two rings of mountains and a vast desert place known as Area 51.

This town, known as Dream Land, is so off limits that the red flag flyers, who are the real top gun pilots, can not fly this zone.

A man known as Bob Lazar, an Electro Physicist, states he has been there. It is a place that is heavily guarded by fences and electric surveillance. Bob Lazar was brought in to inspect a flying saucer. He said "It was obvious what was in the hanger as you could see about three quarters of the edge of the craft, it was a typical flying saucer, what I mean by this is the type you would see in a cartoon."

According to Mr. Lazar, the government has in it's possession nine flying saucers, one which he inspected and said that "Human hands did not put this together, the technology was far beyond anything we have, just the reactor and power source alone put out a tremendous amount of power. The fuel the reactor uses is a super heavy element, 115 on the periodic chart. There again, this is a substance we can't even synthesize on earth, it doesn't exist here."

Ten years ago this stretch of Area 51 was the research and test site of the Stealth Fighter and Stealth Bomber, and as well as ground zero for nuclear tests. If the government had a UFO they could hide it there.

Mr. Lazar said "Beyond a reason of a doubt these are alien space crafts, I have no doubt in my mind." But he could not keep it a secret, he invited two friends to see. Some days after, security guards at the Nevada Test Site found Mr. Lazar and company outside the grounds. Mr. Lazar's life went to shambles. Governmental co-workers and employers claimed they had never employed a Mr. Lazar. Then his birth certificate vanished, his life just disappeared. The Department of Energy, who holds jurisdiction over the Nevada Test Site had no comment on UFO's or Mr. Lazar.

Bob Lazar's story could be fantasy, but the little town of Rachel, Nevada, believes him whole heartily. They came to an inn known as the little "A'LE'INN" to tell of strange lights and show photo's. There is even a bus tour that takes you to see the lights in the sky. The only question left, is Bob Lazar taking us on a magical mystery tour to fantasy land, or is he opening a door to a true tomorrow land.

Compiled by Chief Engineer Lt. Mark Griffeth

TRIVIA

1. NAME THE LAST EPISODE OF THE NEXT GENERATION'S SECOND SEASON.
2. HOW LONG WOULD IT TAKE THE ENTERPRISE TO REACH THE NEAREST STARBASE FROM GALAXY M-33?
3. WHAT IS CODE 47?
4. NAME THE EPISODE WHERE GENERAL ORDER 1 IS QUOTED?
5. WHO FIRST PERFORMED THE COCHRANE DECELERATION MANEUVER?
6. NAME THE SHIP WHOSE RECORDER MARKER WAS FOUND BY KIRK AND THE ENTERPRISE
7. WHO WERE THE TWO MEN TORTURED AND KILLED BY THE VIANS?
8. WHO DIED OF HAPPINESS?
9. HOW ARE THE DISHES WASHED ON RIGEL XII?
10. HOW MANY MOVES DID IT TAKE KOLRAMI TO DEFEAT RIKER AT STRATEGEMA?
11. WHAT IS CHIEF O'BRIEN'S FULL NAME?
12. WHAT IS THE NAME OF THE PEACE TREATY BETWEEN THE FEDERATION AND THE SHELIAK?

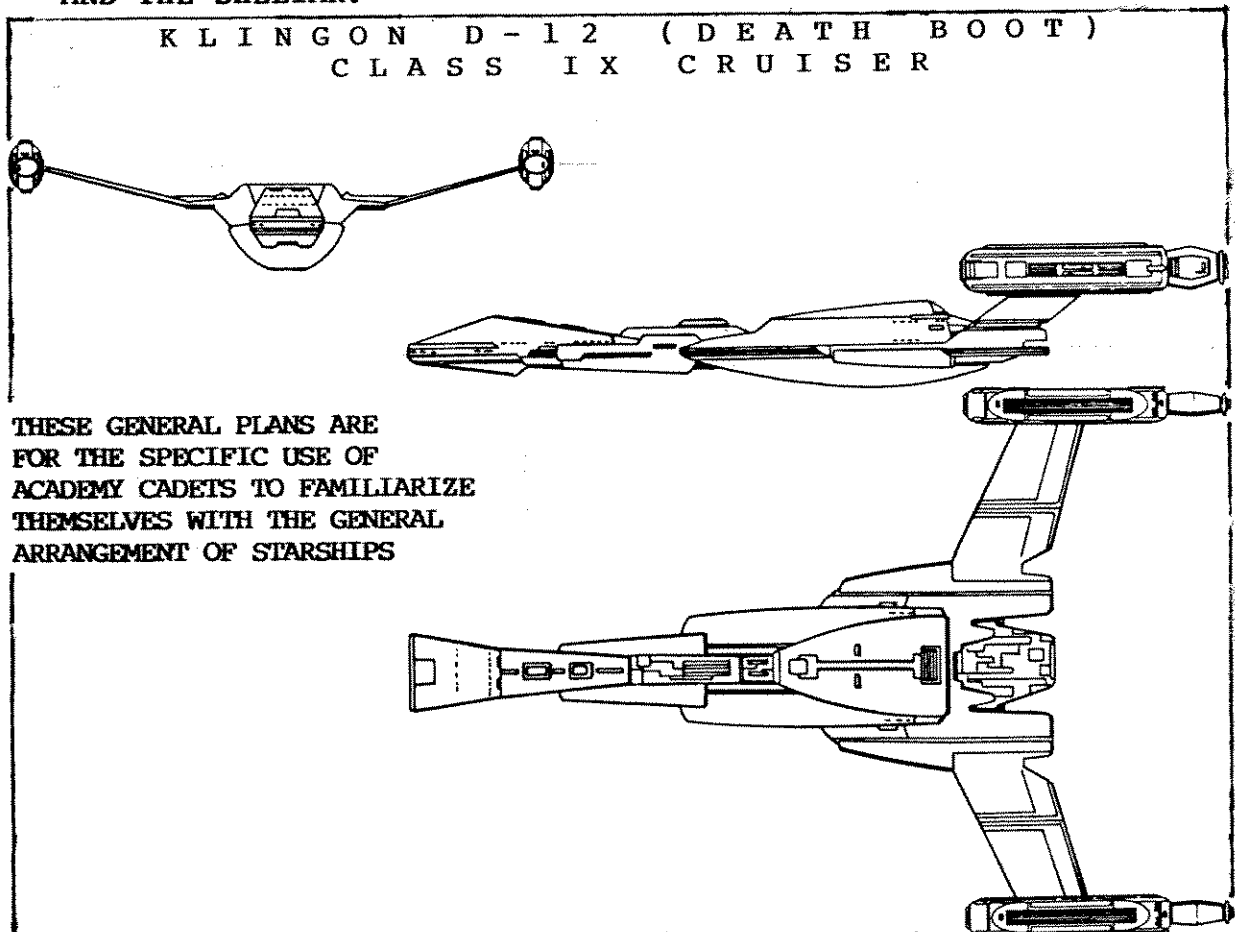

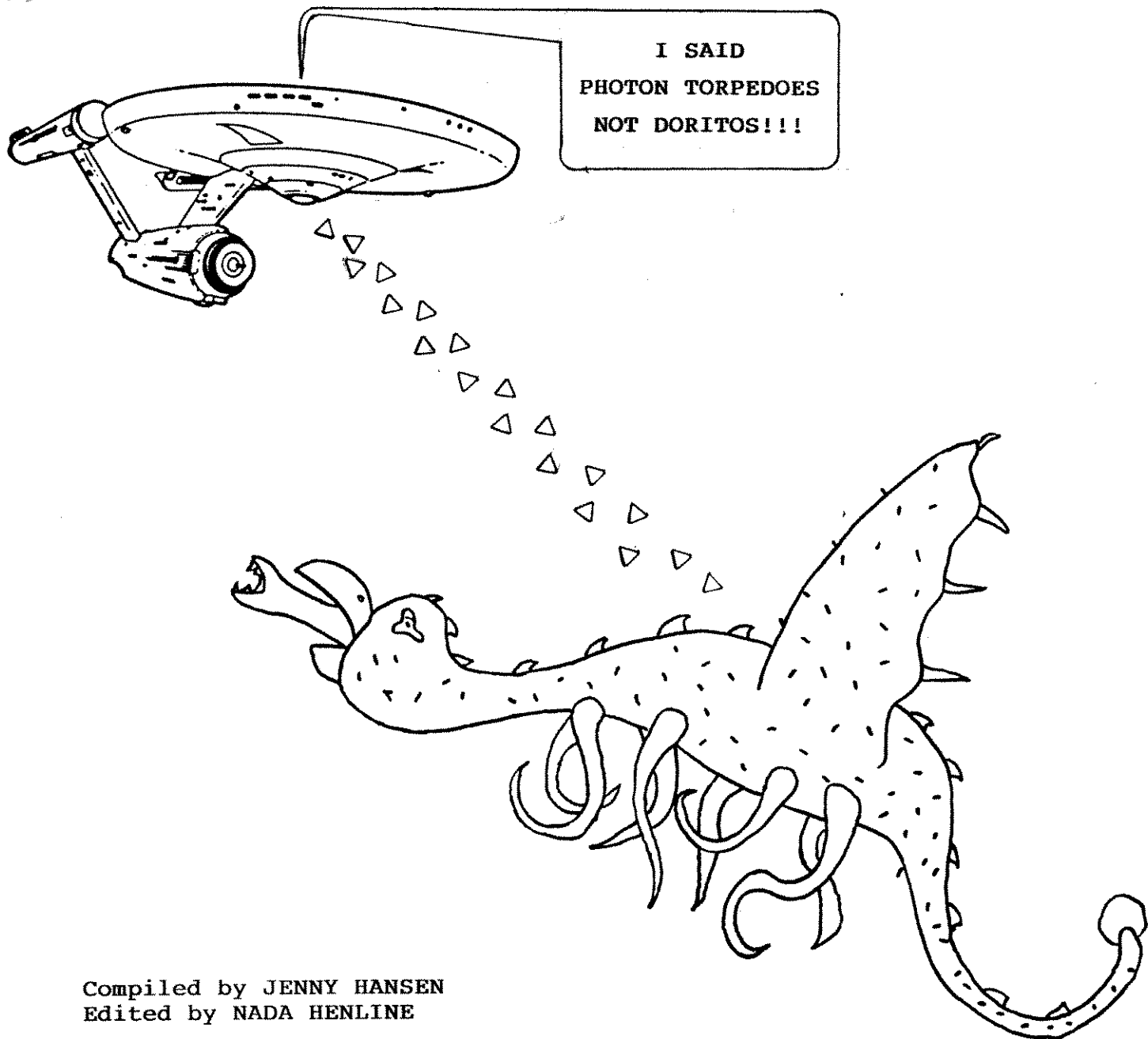

Compiled by JENNY HANSEN
Edited by NADA HENLINE

HAILING FREQUENCIES CLOSED

QUOTE OF THE MONTH
"THE PREJUDICES PEOPLE FEEL ABOUT EACH OTHER
DISAPPEAR WHEN THEY GET TO KNOW EACH OTHER."
KIRK in ELAAN OF TROYIUS