

# KELLY

# DIRECTIVE

NEWSLETTER OF THE I.S.S. KELLY, ILC-3400 VOLUME TWENTY-FIVE NOVEMBER/DECEMBER 1993



TRAITOR TO THE PEOPLE:  
WANTED FOR CRIMES AGAINST THE  
EMPIRE!

# LOG ENTRY

**CHIEF SECURITY OFFICER'S LOG: STARDATE: 47110.1**

(This is the last log entry left by former Chief of Security, Lt. Stark)

I recently had the opportunity to witness a special event. On October 9th the leaders of several Special Interest Groups (Fan Clubs) got together to discuss items of mutual interest. Each club introduced themselves and their command structure. There were discussions on rumor control, and ways on improving relations between clubs.

This meeting was a great success and will be repeated every three months. I'm very impressed with the possibility of seeing the Kelly work along side the other clubs such as the U.S.S. Fahrion, The Camarilla, and/or Rebels Associated in helping our community and just having fun.

So how can we, as members of the U.S.S. Kelly, help the Command Staff in this endeavor? First, please **DO NOT** believe or contribute to rumors. I have seen too many rumors that hurt people and kill ideas before they have a chance to shine. If you have heard a rumor that bothers you. Contact your Commanding Officer or Commander Richard Henline at 562-2359 and they will work out any problems. Also do not pass rumors on to your fellow crewmembers or to people outside of the Kelly. Second, if you have an idea of a project/activity with another group. Make sure that you turn in a written proposal to your Commanding Officer. Your Department Head approves activities for the department and the Command Staff approves activities for the entire ship. **DO NOT** make commitments for the ship with out checking with your Commanding Officer first. And finally please remember the most important issue. Have fun. That's what we are here for.

Lt. Carl Stark

**CHIEF SECURITY OFFICER'S LOG: IMPERIAL STARDATE: 47110.1**

Chief of Security Lt. (j.g.) T. D. Boone reporting

This is my first official announcement as the new Chief of Security on board the I.S.S. Kelly, seeing as Lt. Stark had an unpleasant accident while, uh, shaving...Well, what can I say, command feels good...Nice office! Well fortunately, my first duty as Chief of Security was ordering the executions of rivals Crewman Nielson, Ensign Harvey, and, I am proud to say, the final destruction of that idiot Bob Q. Dinklemyer! They are ordered to be put to death within the week.

Now, on a darker note, I have heard that many of the department question my abilities as a leader. This will not be tolerated! In my opinion, it is the same as questioning the leadership of the Emperor himself! If they have problems with the way I run Security, they should feel free to come to me and tell me about it. They may also feel free to join Nielson, Harvey, and that nit wit Dinklemyer.

I have also heard reports of plots for my assassination. These fools obviously didn't hear about what happened when we went to take care of the mutinous crew of the I.S.S. Rendezvous. Well, it's their own funeral (pun intended) for they will learn of my cunning with an assault phaser if they try to murder me. (heh heh heh)

Earlier I spoke of how nice this office, though cluttered, is. I wonder how the Captain's office feels. I wonder where Ruben is, I ordered him to clean this office up! With how messy this place is, it's a wonder I'm still alive. At least a dozen booby traps could be hidden here. (\*door chime\*) Oh! That must be him at the door now...

TIME DELAY  
LOG ENTRY ENDED



# ASK NUMBER ONE

The question has been asked, "What do we know about alternate universes and where can we find out more?" In the scientific community, the existence of alternate universes has not been proven. There seems to be no way to prove that they are there. That is not to say that scientists and philosophers don't believe in them, just that they don't have proof. Their theories and hypotheses vary widely, everyone trying to explain why their idea is more plausible. Alternate universes are sometimes used to explain the disappearances in the Bermuda Triangle, the lost city of Atlantis, the location of the lost Ten Tribes of Israel, and many other strange occurrences and phenomena.

The science fiction community is not under burden of proof. They simply expound upon the idea that there are alternate universes, and expect the reader or watcher to believe. Numerous authors have developed stories around the idea of alternate universes, and also many science fiction shows have depicted their version of other universes than ours. When thinking about Star Trek, three episodes stand out as alternate universe stories: "The Tholian Web," "The Alternative Factor," and, of course, "Mirror, Mirror." Although vastly different in story line, there are common elements in each of these episodes. For instance, in order to get from one universe to the other there must be some cataclysmic event, such as a collision or explosion to rip a hole in the fabric of space. In "Mirror, Mirror," of course, it was a terrible ion storm coupled with the dreaded transporter malfunction. Why is it that someone can't just travel from one universe to another? There is also something terribly wrong with these other universes. In "The Tholian Web," when the Defiant interphased with the other universe, the crew went mad and killed each other. The "Alternative Factor" pitted two identical men against each other. One was from a positive universe and the other from a negative one. If the two universes ever come into contact with each other, they'll both be totally annihilated. And wasn't that a nice little universe that Captain Kirk and company ended up in on the I.S.S. Enterprise? Why is it that the citizens of other universes look an awful lot like us, but down inside, they're totally opposite? It would be interesting for a change to see the Enterprise travel normally into an alternate universe where the people are just ordinary people and the crew never once meet themselves there. But, I guess that's just not enough science fiction.

If you want to know more about alternate universes, there are plenty of stories concerning them. Or you can pick up a science textbook or perhaps a popular science magazine. I think that it would be interesting if someone were to ask Stephen Hawking's opinion about alternate universes. In his alternate universe, he'd probably find himself playing poker with Albert Einstein and Sir Isaac Newton on a 24th Century starship.

If you have a question and you'd like an answer, just **ASK NUMBER ONE!!!**

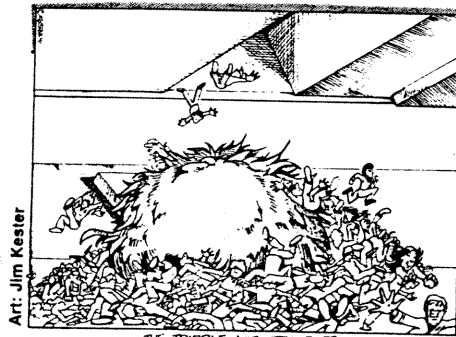

Art: Jim Kester

THE TRIBBLE WITH TROUBLES

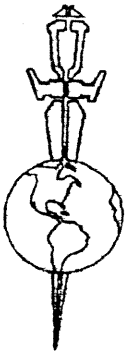

COVER STORY

# Latest move adds twist to bidding war

Some experts doubt the venture can reach enough homes to be successful

By James Cox  
USA TODAY

Paramount Communications, maker of two *Star Trek* TV series, is boldly going where it declined to go a decade ago.

Paramount said Tuesday that it will launch a television network in partnership with Chris-Craft Industries. Between them, Paramount and Chris-Craft own or control 15 TV stations, 10 of which will serve as the cornerstone of the Paramount Network because as independents they are not affiliated with ABC, CBS, NBC or Fox.

Industry experts question whether Paramount and Chris-Craft can reach enough homes to call their venture a true network. And Wall Street analysts suggest that Paramount may have timed the announcement to boost its effort to be acquired by Viacom, which owns cable TV systems and the MTV, VH1 and Nickelodeon cable networks. "There's really not much substance to what (Paramount) said," says Jessica Reif, analyst at Oppenheimer. "Anybody could do this."

Paramount says it has been working on the fifth network concept for more than a year.

"This is something we would have done independent of Viacom," says Kerry McCluggage, chairman of Paramount's TV division. He says Viacom's TV stations wouldn't make much difference because most already are affiliated with networks.

But the announcement does add a twist to the bidding war for Paramount, which is the object of competing tender offers from Viacom and QVC Network, a home-shopping

service. In 1983, Paramount CEO Martin Davis declined to act on a proposal for a new network when it was brought to him by one of his then-lieutenants. Today, that lieutenant, QVC Network CEO Barry Diller, is behind a hostile offer for Paramount, and he is widely believed to have his own plans for a Paramount network.

The relatively high price of QVC stock — up 1 1/2% to \$55 1/2 Tuesday — is proof Wall Street is impressed with Diller's record as an executive at Paramount and later at Fox, where he oversaw the launch of Fox Network. Analysts say Davis may be trying to show Paramount shareholders the company doesn't need Diller to capitalize on its entertainment assets.

The Paramount Network is sure to face tough challenges before its scheduled launch in January 1995. It needs to:

► Recruit Paramount affiliates from among the 422 independent commercial TV stations around the country.

► Arrange for Paramount Network shows to air on cable channels in areas where Paramount doesn't have an affiliate.

► Convince big advertisers that the new network will reach the viewers they want to reach.

► Develop or buy TV programs to air on the network. Initially, the Paramount Network will offer programming for only two hours a night, two nights a week. One of the hours will feature *Star Trek: Voyager*, a spinoff of two other *Star Trek* series that Paramount produces for syndication.

In the industry, to truly be considered a network, Paramount needs to reach at least 75% of U.S. homes. The 10 Paramount and Chris-Craft stations acting as the springboard for the network reach only about 27% of the nation's homes.

"At 27%, you're not a player at all. You're not considered anything other than a superstation or a big regional network," says Paul Schulman, who buys commercial time for network advertisers. Experts say Paramount will need months to assemble a lineup of stations in the top 75 TV markets.

Paramount says it already is courting potential affiliates. But Rupert Murdoch picked off many of the best independents when he formed his Fox Network in 1987. And unlike Fox, Paramount can expect stiff competition.

Time Warner is expected to unveil its own plans for a network within two weeks. It may be better positioned than Paramount to start one.

Time Warner is planning to announce a lineup of affiliates that gives it the ability to reach more than 75% of U.S. homes. The foundation of the Time Warner network is expected to be the seven Tribune Co. TV stations in New York, Los Angeles, Chicago, Philadelphia, Atlanta, Denver and New Orleans. Its architect will be Jaime Kellner, who, along with Diller, put together the Fox Network.

Time Warner's Warner Bros. Television unit is the biggest supplier of network programming, producing *Murphy Brown*, *Full House*, *Lois & Clark: The Adventures of Superman* and other shows.

"Even if (Paramount) got every independent station currently not committed to one of the four networks, they would still be talking about only 70% of the households" in the USA, says David Poltrack, senior vice president at CBS.

Paramount and Time Warner, like Fox, can be expected to fill geographic holes in their viewership by signing cable operators. In doing so, Paramount could find itself at an alarming disadvantage. Tele-Communications Inc., the nation's largest cable operator, is not likely to be much help. TCI is a partner in QVC's bid for Paramount, and the cable operator is being sued by Viacom, which claims TCI violates antitrust laws.

As for the No. 2 cable operator, that's Time Warner, which won't be anxious to help launch a rival network. Time Warner also is in talks to buy all or part of Cablevision Systems, the No. 3 cable company. Further down the line, the Nos. 5 (Comcast), 6 (Cox) and 9 (Newhouse) cable companies all are financial backers of QVC's bid for Paramount.

Whether he wins Paramount or not, QVC chief Diller may launch his own network. The crowded field, says Schulman, means "we may not end up with a fifth network — we may have four-and-a-half networks."

Contributing: Jefferson Graham

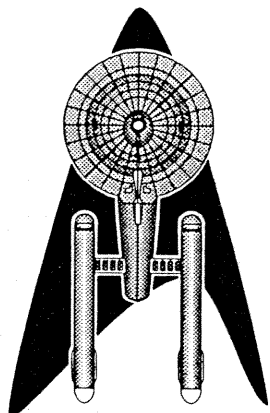

## Paramount airs big plans

Paramount and partner Chris-Craft are planning a fifth television network, set to launch in 1995.

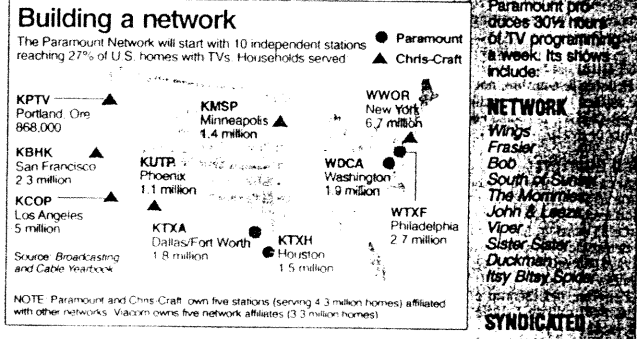

Paramount produces 30% of network TV programming a week. Its shows include:

- ### NETWORK
- Wings*
  - Frasier*
  - Bob*
  - South of Beach*
  - The Monty Python*
  - John & Lesca*
  - Viper*
  - Sister Sister*
  - Duckman*
  - Itsy Bitsy Spider*

- ### SYNDICATED
- Star Trek: The Next Generation*
  - Star Trek: Deep Space Nine*
  - Entertainment Tonight*
  - The Untouchables*
  - The Arsenio Hall Show*
  - The Maury Povich Show*
  - Hard Copy*



Paramount Pictures  
**ARSENIO HALL:** Paramount produces show.



By Robbe Robinson  
**'DEEP SPACE NINE':** New network to take this show into next generation with spinoff called 'Star Trek: Voyager.'

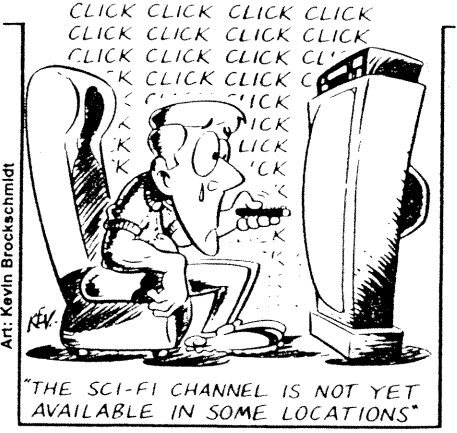

Art: Kevin Brockschmidt

"THE SCI-FI CHANNEL IS NOT YET AVAILABLE IN SOME LOCATIONS"

Interview with CTM David L. Powell

It's always fun to talk with someone who enjoys his work, and Chief Torturer's Mate David L. Powell, highest ranking enlisted man in the Physical Correction Subdivision of the ISS Kelly's Security Division, is such a man.

"I truly enjoying using my artistic and technical skills fully in the service of my Emperor", he said, smiling widely as his scars permit. "I've always known what my profession would be. I was able to pull one wing off a fly without killing it before I could walk. My middle school science project, keeping disemboweled cats alive, set records which stand to this day."

"How did I get my job? Well, my predecessor was wise enough, when we threw him a birthday party, not to be first to use any of the bottles of liquor we gave him. But he did use the prostitute I hired. The poor girl actually believed the contact poison I put on her was his favorite perfume. Of course, today I'd use one of the new, gender-specific poisons -- her death served no particular artistic or political purpose."

"Except", he grinned, "to remind us that life belongs to the strong and smart."

"Family life also brings me a great deal of pleasure. My present wife is of a convenient size to discipline by hand. I'm proud that my son is so well-respected that he was unopposed as captain of the football team"

He laughed off a question about an institutionalized daughter with: "I have no use for weaklings."

Asked about former wives, he replied "No surviving ones", with a reminiscent chuckle.

"I'm glad to be an enlisted man, not troubled with the higher-level decisions about whom to discipline."

"Fat, bald? The last reporter who wanted to say those things about me is no longer suited for such a high-level position. Many in my profession like to work on genitalia, which makes sense in the short term because of the concentration of sensory nerves there. But in the long term, human beings use their hands much more often. A properly worked on pair of hands can leave a man so restricted as to be scarcely human."

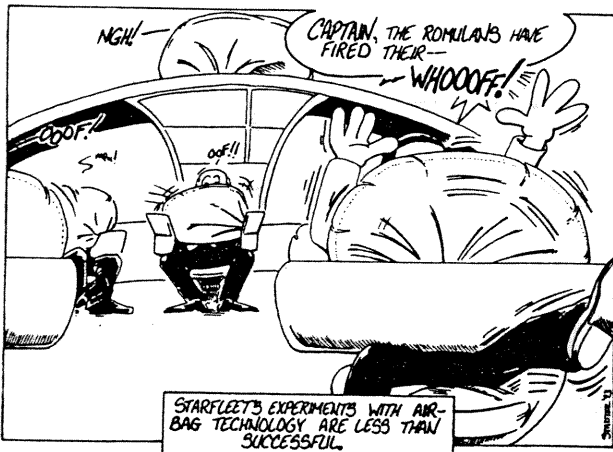
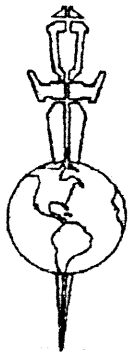

# Theleth Class Missile Cruiser

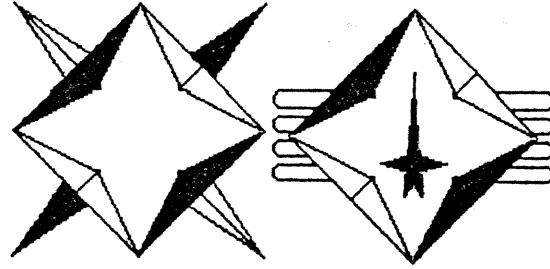

DESIGN BY LT. (J.G.) T.D. BOONE

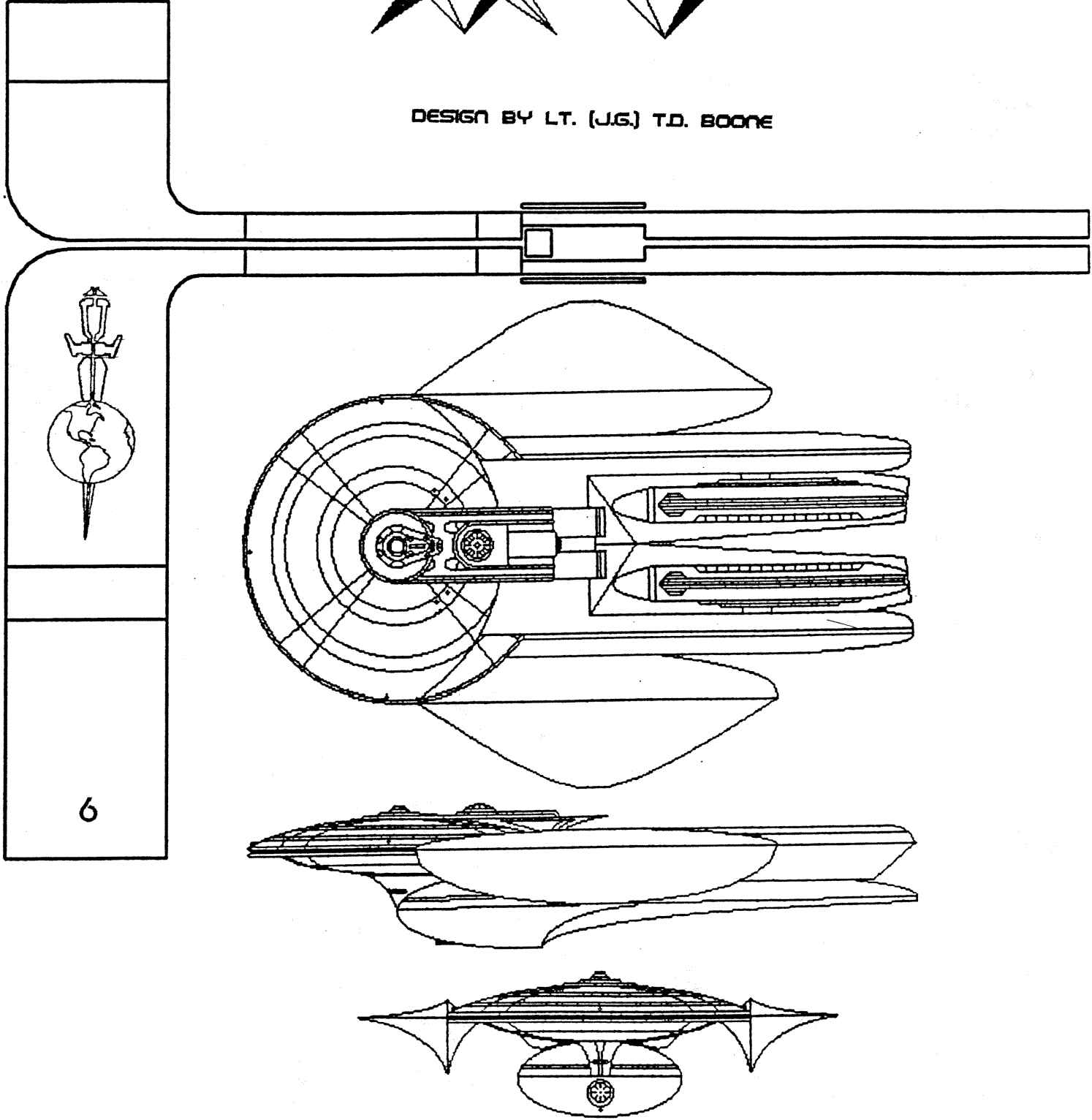

VEHICLE IDENTIFICATION INDEX  
 SUBJECT: THELENTH CLASS XIV MISSILE CRUISER

**SPECIFICATIONS:**

MODEL NUMBER- MK I  
 NUMBER CONSTRUCTED-19

HEIGHT- 75M  
 WIDTH- 27.5M  
 LENGTH- 400M  
 WEIGHT- 247,500 MT

CREW- 467  
 MARINES- 100

**SHUTTLECRAFT:**

STANDARD- 2  
 ASSAULT- 2  
 HEAVY- 2  
 ARMORED- 3

**FIGHTERS:**

FIGHTERS- 2  
 KILLER BEES- 2

WARP ENGINE TYPE- FTWD-2  
 MAX.SAFE CRUSING SPEED- WARP 12 \*  
 EMERGENCY SPEED- WARP 14 \*  
 \*= OLD WARP SCALE

PHASER COLLIMATORS- 3  
 FIRING ARCS- 1F/P,1F/S,1A  
 PHOTON TORPEDO TUBES- 11  
 FIRING ARCS- 3F,1F/P,1F/S,1P,1S  
 1A/P,1A/S,2A

**DISPOSITION:**

USS THELENTH	NCC-29000
USS DOMINGUEZ	NCC-29001
USS WESLEY	NCC-29002
USS FOX	NCC-29003
USS KIRK	NCC-29004
USS STONE	NCC-29005
USS BARSTOW	NCC-29006
USS HARRIS	NCC-29007
USS SATAK	NCC-29008
USS ENWRIGHT	NCC-29009
USS MENDEZ	NCC-29010
USS FITZPATRICK	NCC-29011
USS APRIL	NCC-29012
USS KOMACK	NCC-29013
USS TRAVERS	NCC-29014
USS WESTERVLIT	NCC-29015
USS GARROVICK	NCC-29016
USS FITZGERALD	NCC-29017
USS HANSEN	NCC-29018

**NOTES:**

Based on the old Andor Class Cruiser. The Thelenth Class XIV Missile Cruiser was one of the specialty ships for TacFleet after the retirement of the old Andor, Soyuz, & Belknap Class Starships. Manufactured at the Andor and Salazaar shipyards at the rate of two per year. Like the Andor and Thufir classes, the warp engines are mounted close together and center aft of the main hull. Unlike it's earlier sister ships the Thelenth is more compact and heavily armored. This allows the Thelenth to take more punishment than normal. Of the nineteen in service, four have been destroyed. The USS April (NCC-29012) fell to the Cardassians during the Federation/Cardassian War. The USS Wesley (NCC-29002) was destroyed by Tholians. And the USS Enwright (NCC-29009) and USS Travers (NCC-29014) was destroyed at the Battle of Wolf 359. There are plans to build six more Thelenth Class Starships.



**STRONG,  
 INNOVATIVE,  
 LOGICAL**

FIRST VULCAN  
 INTERPLANETARY  
 SECURITIES AND LOANS



## FIRST CONTACT

Personal Log, Recruit Mark Boone  
Stardate: 46051.1

Yesterday was my First Contact with members of the Kelly. I sat in as a recruit during the Security/Engineering Departments' meeting. I must say that I was taken somewhat aback. Television shows, magazine articles, and general lore had led me to expect that I'd find a group of individuals whose fanaticism bordered on obsession. I knew, of course, that the entire idea was silly. Still, when I found the group to be different from my mind's picture, I realized that a bunch of Terminal Trekkers was exactly what I had expected.

Being wrong was pleasant. Before and after the meeting, the conversation topics roamed from upgrading a personal computer and least favorite comic book heroes, to (seemingly inevitable) Monty Python quotes. Perhaps not among the most mainstream conversations in the world, but I felt right at home.

The meeting itself was more focused. After new faces had been introduced, and individual and group merit had been recognized, the departments turned to the task of building rockets. It might have been more productive if more than two people had actually brought a rocket along, but I doubt the meeting could have been more of a success. I had fun. Everyone around me seemed to be enjoying themselves. We laughed, joked, and told stories of various degrees of credibility for hours.

I'm generally shy, perhaps sociophobic, so I didn't do much talking. I suppose I regret that. With as good a time as I had though, I think I'll give myself a second chance on that one by going to the Lunch & Launch. If a dozen crew members leave me with this kind of an impression, I have high hopes for the whole club.

Stardate: 46051.6

The Lunch & Launch was relaxing. I can't think of a better way to put it. I got to meet the commanders, some Kelly members, and some other prospective members. They're a nice group, the lot of them. Things might have gotten a little out of hand with pine-cones flying at random, but at least nobody lost an eye.

Still, though, not what I expected. The meeting seemed to be an excuse to have a picnic and launch rockets more than anything to do with Star Trek or a club's administration. *Definitely* a place I can fit in. I was able to loosen up more than the previous meeting, though I still pretty much stuck near my brother.

I'm not going to go into any specifics about anyone, but I think I can already tell who I'm going to make good friends with. Unfortunately, I think there are some that I won't be able to get along with. I suppose there's that mix anywhere. Everything is just so easy. I truly think I've found a vacation spot for my mind.

To be brief (too late), I'm hooked. I like these people, and I like what they do. I think I'd even enjoy using the term, "I like what we do." I'm in for the long haul.

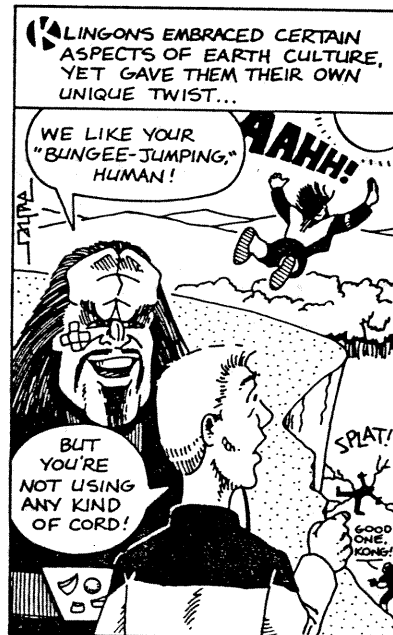



FIGURE THIS ONE OUT!  
BY ENSIGN NESSA HARVEY

Unscramble the letters to form the names of Federation Starships. Worth 2 knowledge points.

- |                |             |            |
|----------------|-------------|------------|
| PESTERRINE     | KEHALOU     | NELRIB     |
| SOBARSDAM      | NIMDAAR     | LEESAFRS   |
| LEXICRUAB      | NETILAR     | TALCRNOSH  |
| LAPEHID        | ASTARGAO    | BEENORMUL  |
| TENARAS        | RATTNIIB    | HAZYCERROS |
| DAYBRUBR       | MAANNITEN   | DEERMOF    |
| LENGERLACH     | LENBAU      | MOBULICA   |
| NEYEHECN       | IRONTOM     | RICLOANA   |
| NEHWEAHA       | IMMCRAER    | DERBARNIF  |
| TALLISNOONCENT | NOPEXIH     | TAYAMO     |
| YATWHAHA       | ERENDAOVU   | ILORTIP    |
| TESGRAAZR      | TERSHALNUD  |            |
| TIROCYV        | EDANEEGR    |            |
| TUGGBRETSHY    | LUDETEGR    |            |
| BIRPELUC       | GELWILNNOT  |            |
| TIPERDIN       | GAARIN      |            |
| TOTUSINCTINO   | CENTNIROP   |            |
| TONMEKIP       | TOOLSYT     |            |
| TELNOGIXN      | SROGSIM     |            |
| TROYWOKN       | HOCRECAN    |            |
| FADNEIT        | MOZNEAB     |            |
| DULDSAAE       | KECVOH      |            |
| NIHZOOR        | REDPIGSNIFL |            |
| LEXISROCE      | MOSTEEYI    |            |
| LEPRUSE        | SITERTE     |            |



Art: Mike Fisher

# IMPERIAL PERSONEL DATABASE

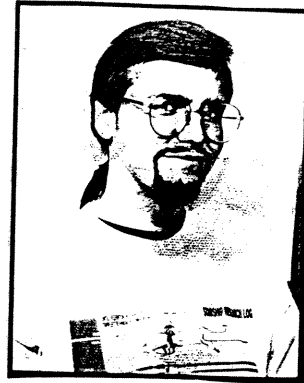

**NAME:** T. D. Boone

**RACE:** Half Romulan / Half Effrosian

**CHARACTER:** T. D.



**Tell us a little about yourself. (Where were you born? Where did you grow up? Tell us about your family. Your occupation. Hobbies. Talents. What is unique about you that is not common knowledge?)**

I was born in Mesa, Arizona, but I grew up in Utah. I don't have much contact with my family. I flip burgers for Omega Burgers. I like role-playing, miniature painting, and model building. I'm very much into rock & roll, and guitar playing, also.

**How did you get interested in Star Trek? (What is your favorite episode or movie? How long have you been a fan? What do you like most and least about Star Trek?)**

Trouble with Tribbles, Mirror Mirror, Samaritan Snare, and Chain of Command part I, Star Trek II, and Star Trek VI. I've been a fan since Star Trek II. I love learning the Klingon language, and collecting memorabilia. I hate Imaginary Friend.

**If you could be any race or character in the Star Trek univers, who would you be? What would you be like? Tell us about your character.**

I am half Romulan, half Effrosian, raised by adoptive parents on Terra. Wanting to find my roots, I went to the Academy to hopefully get on a ship that could get me closer to Romulos. After graduating, I spent three Earth years studying Klingon culture on Kronos. Since then I was assigned to the Cairo under Captain Jellico. From there I went to the fleet yards for work on the Kelly Class project, and I now serve aboard that class ship.

10

# IMPERIAL PERSONEL DATABASE



**NAME:** Nessa Harvey

**RACE:** Bajoran

**CHARACTER:** Haro Nishar



11

**Tell us a little about yourself. (Where were you born? Where did you grow up? Tell us about your family. Your occupation. Hobbies. Talents. What is unique about you that is not common knowledge?)**

I was born and raised in Utah. At the age of 18, I joined the US Army - Active duty. After two years of painful hell, I drove back to Utah to join the Kelly. I always enjoyed ST, but didn't get "into" it until I joined the armed forces. I collect music boxes and ST, and spend time writing short stories, poetry, and songs. I love to sing and share my talent with others.

**How did you get interested in Star Trek? (What is your favorite episode or movie? How long have you been a fan? What do you like most and least about Star Trek?)**

When I was very young, I used to watch ST with my father. Of course, they were re-runs, but I was young and didn't care. One weekend, my father was gone on a hunting trip, and since there was no one to turn the T.V. on. Well, it was ST, and so I turned it on. I've been a fan ever since, and enjoy the classics most. Funny, but my favorite episode is "Inner Light" (TNG). Chekov is my favorite character, and I like the idea of peace and hope conveyed in the show.

**If you could be any race or character in the Star Trek universe, who would you be? What would you be like? Tell us about your character.**

I am Bajoran, and proud to be so. My parents were killed in a Cardassian attack. My younger brother, Jo, and I escaped and went to Earth where we were adopted by a Terran family. I wished to leave Earth and find *something* to believe in, and, thus, joined Starfleet.

This subspace message was received during a battle-skill training operation. It was de-coded and sent to high command for further evaluation.

During a most recent event with the Argellians, a peaceful race among us, I encountered an opportunity to meet with their leader, Paritze Noart Revall. He spoke of matters of trade and commerce, I spoke of war and conquering. The following is a report to Imperial Starfleet Command concerning this encounter.

To Admiral Adam T. Odin:

I must regret to inform you, sir, that negotiations with the Argellians have failed. I met with Paritze Revall on stardate 47039.1, to discuss terms of surrender that Imperial Starfleet might colonize and mine the planet for any minerals we see fit to utilize for our own prosperity, and develop a military base to defend the boundaries of the ever-growing Empire. The Paritze seemed to be most appalled by this act of generosity on our behalf, and bid me to leave the star system. I beamed back aboard my vessel and waited until he was in a more agreeable mood to continue talks.

After what seemed to be an eternity, I hailed the man to once again demand the surrender of his people, commerce, and land. And, once again, he refused to talk with me, claiming "freedom and rights for the citizens of Argel III." This act, being completely unfounded, struck me as unnecessary and boring. I warned the Paritze that if he did not agree to the terms set forth by the Galactic Empire, of which organization his world was a member, I would have to take further action to ensure the success of my mission. I also transmitted those terms as agreed upon by Imperial Command, and included in my orders.

My Chief Communications officer informed me that the planetary defense systems were coming on line, and I ordered a full phaser and photon torpedo spread aimed at the capital city before any shields could come online. Unfortunately, this is when my Tactical Officer decided it would be a good time to get promoted and attempted assassinating my Chief Helmsman. I had the Tactical Officer taken to the torture room for later punishment. I did not have time for this foolish act. By this time, the planetary systems had come online, and I could only wait for my Chief Engineer to break through their defenses.

This delay gave me time to punish my third in command. Heading for the torture room, I encountered two crewmen locked in personal battle in the corridor. I tried to pleasantly inform them that this type of activity should only take place in personnel quarters, the rec room, and holodeck, but one of them started to pull a phaser on me, so I was forced to kill them both. Getting on my way, I managed to make it to the torture room without much further delay. Of course, the Lt. Commander tried to explain that he was really aiming for me, rather than the Lieutenant, hoping his punishment would be lessened. I, however, took no mercy in his pleas, and watched the man die a slow, painful death.

I was then recalled to the bridge for more pertinent matters. The engineers had successfully broken through the field, and I ordered open fire on the planet below. Because my trained Tactical Officer had shown less than worthy attributes, the junior tactical trainee did not use caution, and completely destroyed the complete Northwest continent. I was forced to kill him, too, for ruining the planet's surface.

I was able to leave a handful of specialists on the planet's Southern continent to enslave the remainder of inhabitants and start the ever-frustrating task of working together to establish a working colony before the arrival of the I.S.S. *Shotgun*.

My apologies, sir, as I leave you this bad news about losing most of the inhabitable land on Argel III, and the sincere hope that it will not affect any of my future assignments. Due to the loss of several crew members on this mission, I request new personnel assignments at starbase 114 when we arrive. I require seven engineers, crewmen all; two communications specialists; two tactical trainees, and a new Tactical Officer. It is my deepest regret that the casualties onboard were as few as they are, and I hope that our next mission will bring more prosperity to the Galactic Empire.

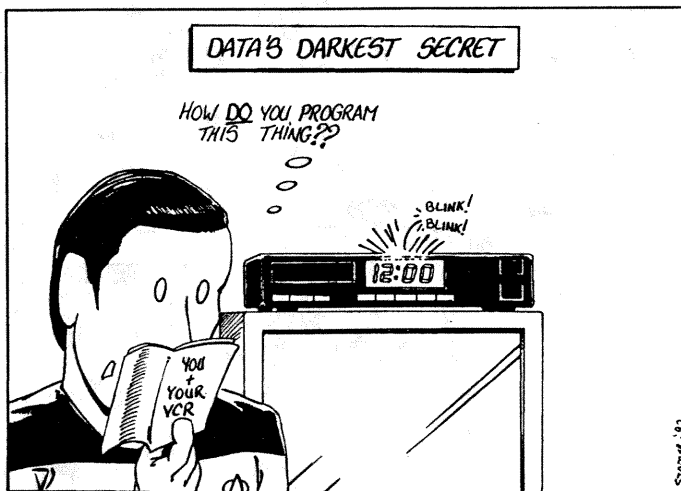

Captain Don O. Good  
I.S.S. *Bloodshed*  
Imperial Starfleet

MIRROR, MIRROR WORD SEARCH  
BY ENSIGN NESSA HARVEY

Worth 2 knowledge points.

3 Letters

SEX  
WAR

4 Letters

DARK  
FIRE  
KILL  
RANK  
RAPE

5 Letters

ANGER  
GREED  
SHOOT  
TOTAL

6 Letters

BROKEN  
COMBAT  
COMBAT  
HATRED  
MUTINY  
PHASER  
PROFIT

7 Letters

DISEASE  
ILLNESS  
PHYSICS  
SLAVERY  
TORTURE

8 Letters

COMMANDS  
DISTRUST  
UNIVERSE  
FUTILITY  
SINISTER  
STRUGGLE

9 Letters

ALTERNATE  
ANIMOSITY  
DISREGARD  
DISRUPTOR  
HOSTILITY  
SUPREMACY  
SYMBOLISM

10 Letters

ASSASSINATE  
PROSPERITY  
PUNISHMENT  
RESISTANCE

11 Letters

ANTAGONIZER  
DESTRUCTION  
INTERROGATE  
REGULATIONS

12 Letters

ASSIMILATION  
ANNIHILATION  
MIRROR, MIRROR  
UNSTRUCTURED

14 Letters

COMMUNICATIONS  
COUNTERMISSION

15 Letters

PHOTON TOPEDOES

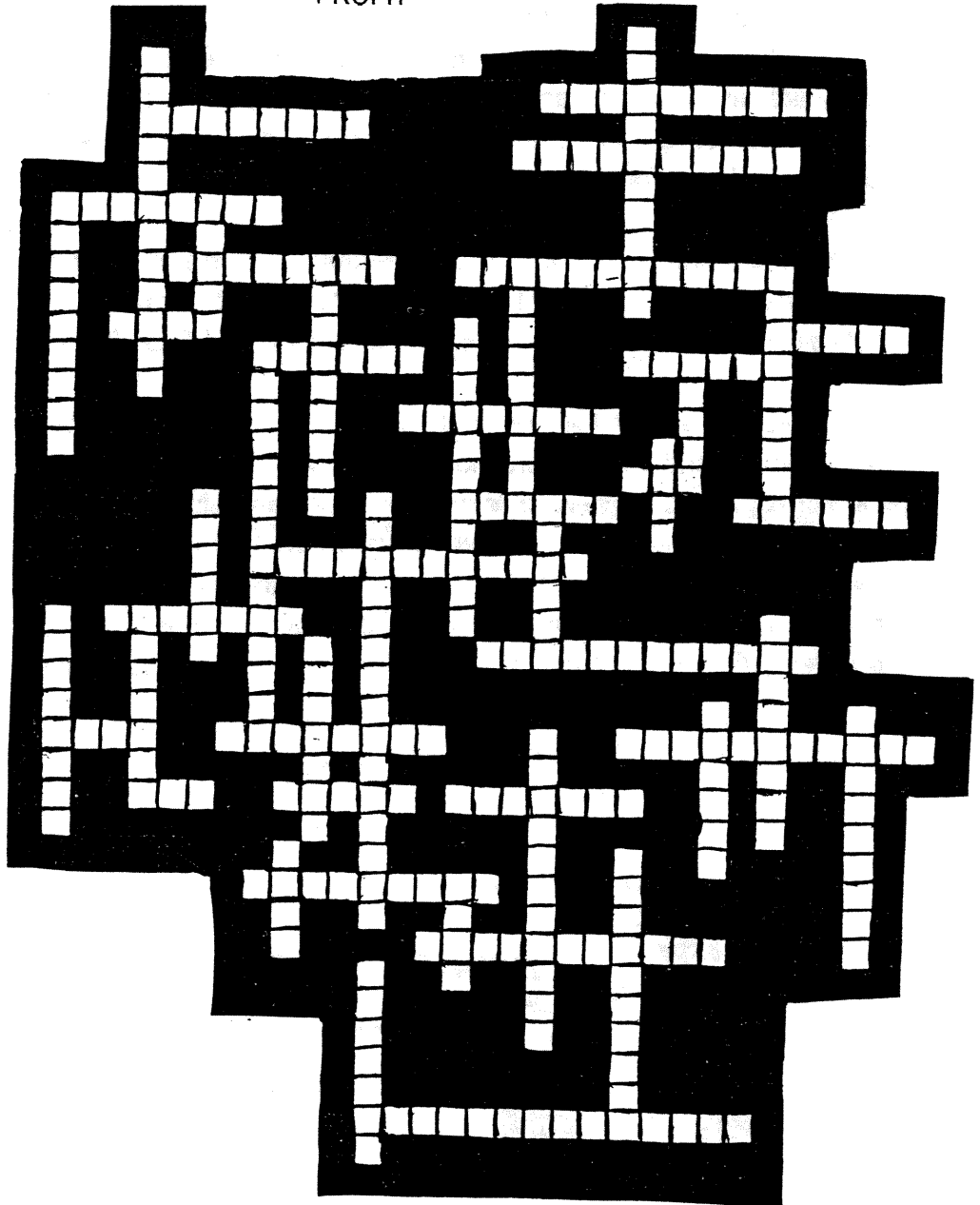

## FOR YOUR INFORMATION

**CONVENTIONS:** 1993 - November 14th *Creation Convention* in Albuquerque, New Mexico. Guest: Marina Sirtis. For more information call Creation Entertainment at 818-409-0960. December 11th *Creation Convention* in San Bernadino, California. Guest: Michael Dorn. 1994 - January 8th-9th *Creation Convention* in Sacramento, California. Guest: Brent Spiner. February 16th-19th *Life, The Universe, & Everything* at BYU in Provo, Utah. Guests: Roger Zelazny, Katherine Kurtz, & Robert L. Forward. Cost: \$15 until Feb. 12th, \$20 at the door. For more information call 1-378-2456. February *Creation Convention* in Las Vegas, Nevada. Guest: Nana Visitor. March 18th-20th *Star Trek: The Grand Slam Show II* in Pasadena, California. Held at the Pasadena Civic Center by Creation Entertainment. 30+ Guests. For more information call 818-409-0960. April 8th-10th *Starfest 94* in Denver, Colorado. Guest: Patrick Stewart. For more information call 303-671-8735. May 13th-15th *CONduit 4: King CONduit.* at the Quality Inn in Salt Lake City, Utah. Guest: C.J. Cherryh. For more information call Dave Powell at 467-9517.

**FOR SALE:** Subscriptions to the *Kelly Communique* are still \$8 a year. Individual price for the Communique has been raised to \$1.50 per issue. Back issues are available from the Command Staff. And remember every Communique purchased is worth 2 knowledge points. The Henlines also have a cardboard replica of the *USS Enterprise* for sale. Interested parties call 562-2359 and make an offer. Kelly Keychains are also available from the Command Staff for only \$5.



### IRW RIHANNSU

**OTHER SHIPS:** There is a new ship forming in the Ogden area. The *IRW Rihannsu* under Sub-Commander Janet Donovan is associated with the Romulan International Empire out of North Carolina. In Layton the *USS Romulus* is being commissioned on December 7th (fitting isn't it?). And finally by the new year both the *USS Fahrion* (Salt Lake) and the *USS Alioth* (Provo) will be experiencing a change in command.

**OTHER NEWS:** The Kelly Activity for the month of November will be a Potluck dinner at the Old Sandy City Hall located at 8680 South and 440 East. The events start at Red Hour (6:00pm) on November 6th. Every household is expected to bring some type of food (salad, main course, or some type of dessert.) Enough to feed six or more people. Also on November 11th the *USS Dominion* is having an anniversary party at the Ogden Eagles Building at 975 Wall Ave. in Ogden. The Kelly is invited to attend. The trivia competition between the *USS Kelly* and the *USS Dominion* will also be held at this time. The anniversary starts at 1:00pm. If you wish to participate on the trivia team. Contact Lt. Rex Rouviere at 566-2725. On November 20th Rex Rouviere is putting on a Gaming and Science Fiction Swap Meet at the South Towne Community Room. From 10:00am-2:00pm. Contact Rex Rouviere for more information. On December 3rd, at about 7:00pm, for the Kelly Activity we will be going to the Festival of Trees. Look around for discount tickets at local merchants. More information on this event will be made available at a latter date. The Robert A. Heinline Memorial Blood Drive will be held on December 13th. For more information call Dave Powell at 467-9517. In the month of May of 1994 we will be attending an 18 hour mission at the Krista McAuliffe Space Educational Center. If you have not put in your deposit for the mission contact the Command Staff and/or your Commanding Officer.

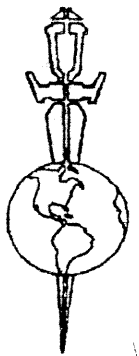



**NOVEMBER**

Sunday	Monday	Tuesday	Wednesday	Thursday	Friday	Saturday
	1 HAPPY BIRTHDAY TORY WHALL	2	3	4	5	6 KELLY ACTIVITY 6 P.M. 440 E 8680 S SANDY BRING \$1 AND POT LUCK DISH
7	8	9 HAPPY BIRTHDAY CAPTAIN HOLLINGER	10 HAPPY BIRTHDAY COUNSELOR HOLLINGER	11	12 SECURITY MEETING	13 HAPPY BIRTHDAY KEN PARK TRIVIA COMP AT DOMINION ANNIVERSARY
14	15	16 STAFF MEETING	17	18	19	20
21	22	23	24	25 HAPPY THANKSGIVING	26	27
28	29	30				



**FROM THE KITCHEN OF ELLI'T:**

NOTE: THE IMPERIAL BUREAU OF COUNTER-ASSASINATION HAS APPROVED THAT THIS RECIPIE, IN IT'S ORIGINAL FORM, HAS NO HARMFULL EFFECTS ON HUMANS.

**AGONIZER SURPRISE**

**INGREDIENTS:**

- 1 Pound of ground tribble (Or ground beef if there are no tribbles available)
- 1 Medium Denibian Onion
- 2 Cans of Cream of Mushroom Soup (Or substitute Cream of Chicken Soup)
- 1 Large or 2 small Cans of Shelat Evaporated Milk
- 2 Teaspoons of Soy Sauce
- 1 Package of frozen Cardassian Noses (Or you can use Tater Tots)

**DIRECTIONS:**

First fry the ground tribbles with chopped onion. Then salt and peper to taste. Drain fat. Put in the two cans of soup, the can(s) of Shelat evaporated milk, and the soy sauce in the meat. Stir untill completely blended together.

Spray a baking dish with Pam and place the tater tots in the dish. Cover tater tots with the meat sauce. Bake for 30 minutes at 350 degrees.

DECEMBER

Sunday	Monday	Tuesday	Wednesday	Thursday	Friday	Saturday
			1	2	3 KELLY ACTIVITY 7 P.M. FESTIVAL OF TREES	4 CONGRATS KEN PARK WEDDING RECEPTION
5	6 HAPPY BIRTHDAY DANNELLE REED	7	8	9	10	11
12	13 BLOOD DRIVE HAPPY BIRTHDAY AMY WULSCHLEGER	14	15 HAPPY BIRTHDAY LIZ BOGUE	16 HAPPY BIRTHDAY ADAM HENLINE AND SUZANNE READING	17	18
19	20	21 STAFF MEETING	22	23 HAPPY BIRTHDAY SHERRIE GRIFFETH	24	25 MERRY CHRISTMAS
26	27	28 HAPPY BIRTHDAY JED SMITH	29	30	31 NEW YEAR'S EVE	

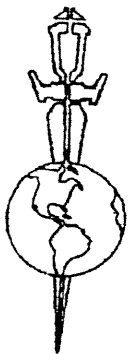

Art: Jason Yungbluth

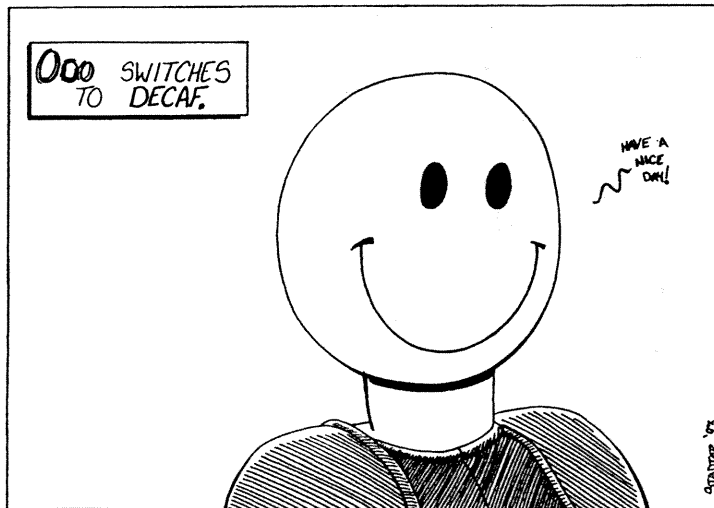

## QUOTE OF THE MONTH

"In every revolution, there is a man with a vision."  
Captain James T. Kirk, "Mirror, Mirror"

## HAILING FREQUENCIES CLOSED

## SECONDARY QUOTE OF THE MONTH

"Your agonizer, Lt. Stark."  
Captain Dennis Hollinger

FINALLY! THE STAMP WE REALLY WANTED TO VOTE ON!



YOUNG BRASH KIRK

OLD CROTCHETY KIRK



KEV

Art: Kevin Brockschmidt

THE KELLY COMMUNIQUE IS A NON-PROFIT NEWSLETTER  
PUBLISHED AS A MEANS OF COMMUNICATION BETWEEN STAR TREK FANDOM.  
IT DOES NOT INTEND TO INFRINGE UPON ANY RIGHTS.  
"STAR TREK", "STAR TREK: THE NEXT GENERATION", "STAR TREK: DEEP SPACE NINE"  
ARE REGISTERED TRADEMARKS OF PARAMOUNT PICTURES CORP.  
ALL RIGHTS ARE RESERVED TO THE ORIGINAL WORK HEREIN.  
NO COPYING WITHOUT THE PERMISSION OF THE INDIVIDUAL AUTHOR.

U.S.S. KELLY ILC-3400  
8782 SOUTH 220 EAST  
SANDY, UTAH 84070  
801-562-2359  
EARTH, SOL SYSTEM



© 1993 Greg Cravens

TO: \_\_\_\_\_  
\_\_\_\_\_  
\_\_\_\_\_  
\_\_\_\_\_