

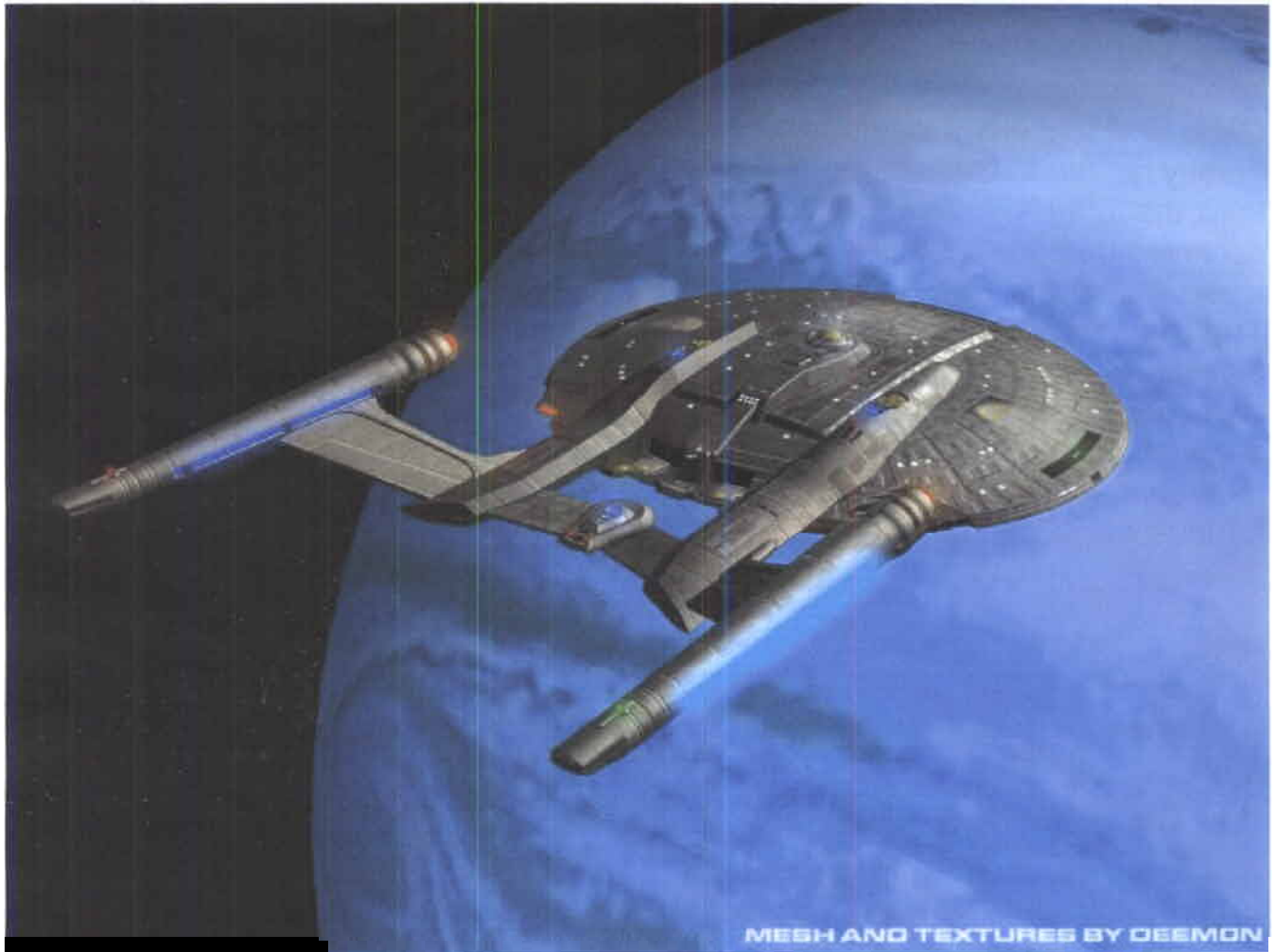

KELLY COMMUNIQUE

ISSUE #61

OCTOBER • NOVEMBER • DECEMBER 2001



MESH AND TEXTURES BY DEEMON

ENTERPRISE

September 26, 2001
Salt Lake City, Ut

CAPTAIN'S LOG...STARDATE 55010.1

As I record this log entry, we are beginning our 16th year as a Star Trek fan club. Many events and experiences have transpired during our first 15 years, and so it was with some trepidation that I approached this milestone. The "Undiscovered Country" is always an uncertain place to go, even though we must all travel that path. I have wondered...what will I do now? How should I plan for the future? And what new experiences will I gain from it? I recently had the opportunity to see a sneak preview of the first episode of "Enterprise." I was somewhat worried that without the title of "Star Trek", it would not live up to the other series' based upon Gene Roddenberry's vision. Having now seen how that episode unfolded, I am greatly relieved. Despite the absence of the title, Enterprise is still Star Trek. I think that the producers wanted a different look to the new series, and they have achieved that goal. But they have tied in many things with the "old" episodes that make it clear this new concept is definitely a legacy of the Great Bird's Dream. The characters fit into a familiar universe, with their own temperament and distinctiveness that adds to, rather than detracts from what has gone before. I was very pleased with how the show was presented and I really think I will greatly enjoy seeing new episodes each week. And who knows? I may get some ideas for planning my future from things that I see on "Enterprise." So, to quote a famous warp drive engineer, let's "Boldly go where no man has gone before!"

---CAPTAIN RICHARD HENLINE, REPORTING---



**THE COUNCIL OF INTERSPECIES AFFAIRS
ATTEMPTS TO IMPROVE THE IMAGE
OF CERTAIN ALIEN RACES.**

**"TELLARITE
...THE OTHER WHITE ALIEN!"**

ASK NUMBER ONE

(a.k.a. "EXECUTIVE STRESS")

By Lt. Cmdr Jill Bogler, Executive Officer

It's hard to believe it's time for another issue of the Communiqué. It's even harder to believe that I am Executive Officer again. It feels like I have just begun to relax after the last time I had this position. Oh well, back to swimming with the piranhas.

For this article, I decided I wanted to revive the old ASK NUMBER ONE column, but *only* if I received questions from the crew. That means this column will be changing titles, depending on if any questions are received. If you want to submit a question, please feel free to contact me (see below). In the meantime...

This issue's question comes from our own CMO, Lt. Stephanie Thalmann, who asks, "If Spock was the first Vulcan in Starfleet, why is there a Vulcan on the new show ENTERPRISE?" The simple answer is "it's in the script". ☺

Not having seen the episode yet, my research indicates that at this point in time Starfleet is a purely human organization. T'Pol (the Vulcan on ENTERPRISE) is there as an observer and a voice of reason, responsibility and logic. She is not, however, actually a member of Starfleet. As Jolene Blalock (T'Pol) put it, "T'Pol is there to make sure they [humans] don't bungle things up." Ms. Blalock also says that T'Pol is unpopular with the crew of the first starship Enterprise because they are so hungry for adventure they don't want to hear a voice of reason.

Hope this answers your question! If you have a question to submit about Star Trek, the U.S.S. Kelly or fandom in general, feel free to [ASK NUMBER ONE!!!](#)

As always, please feel free to contact me about anything.
Contact Info: 685-6154 (home), KellyXO@USWestmail.net

Third Quarter Personnel Activity

Orders:

Leslie Holfeltz (Crewman 3rd), Bart Holfeltz (Crewman 2nd), Dave Kanorr (Crewman 2nd), Molly Reutzel (Crewman 2nd), Dawn Urton (Crewman 2nd), Frank Buck (Lieutenant j.g.)* (*Transfer)

Promotions:

Frank Buck (Lieutenant), Pam Carson (Crewman 1st and Ensign), Molly Reutzel (Crewman 1st), Justin Rouviere (Lieutenant j.g.)

Awards & Ribbons:

Simulator Command Ribbon – Jill Bogler & Stephanie Thalmann.
Simulator Ribbons –George Bogler, Ashley Burton, Lynn Cagle, Scott Cagle, Don Hallett, Richard Henline, Brandon Holfeltz, Fred Provoncha, Mike Read, Jeremy Rouviere, Justin Rouviere, Christy Thorsen. **Star Cross** – Ruth Burns. **Year of Service Pin** – George Bogler (4), Stephanie Thalmann (2)

Bear Awards:

July: George Bogler—Attendance at more Star Trek meetings than anyone, including Admiral Hollinger and Captain Henline.

Aug: Brandon Holfeltz—Actively participating in Star Trek events. Setting the example for youth members in participation.

Sept: Scott Cagle—For developing a knowledge & enthusiasm of Star Trek trivia and studying on his own. Also for being one of the youngest members to do so.



U.S.S. ENTERPRISE

CAPTAINED BY JAMES T. KIRK

LAUNCHED IN THE YEAR 2245

**LEARN TO DRAW THE MOST
FAMOUS STARSHIP IN THE UNIVERSE.
FOLLOW EACH STEP AS OUTLINED,
TO BEGIN AND FINISH
YOUR OWN UNIQUE DRAWING.**

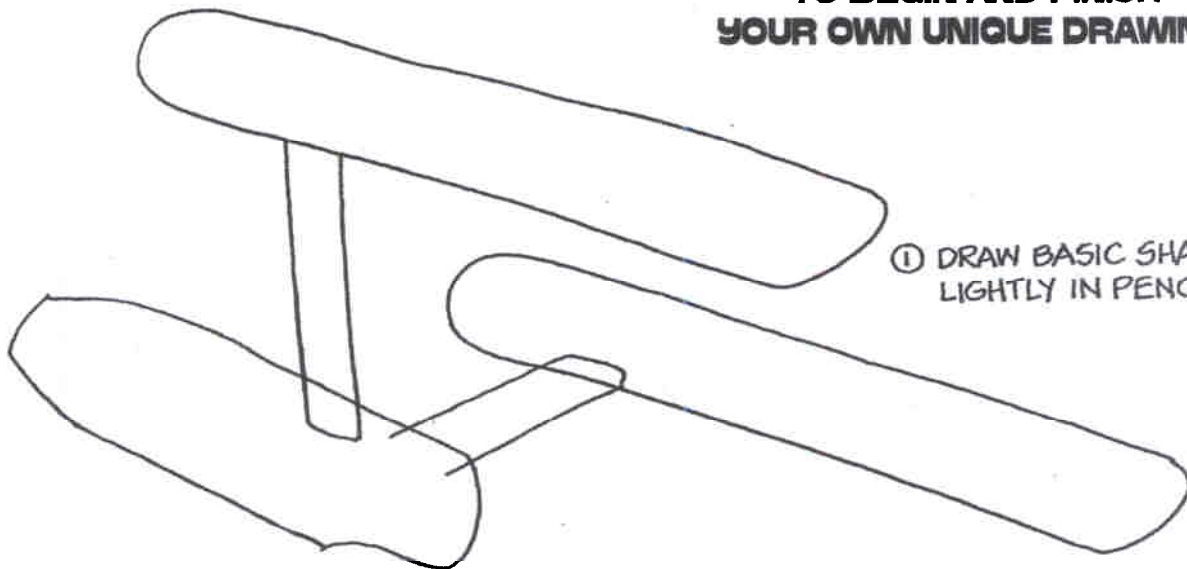

① DRAW BASIC SHAPES
LIGHTLY IN PENCIL.

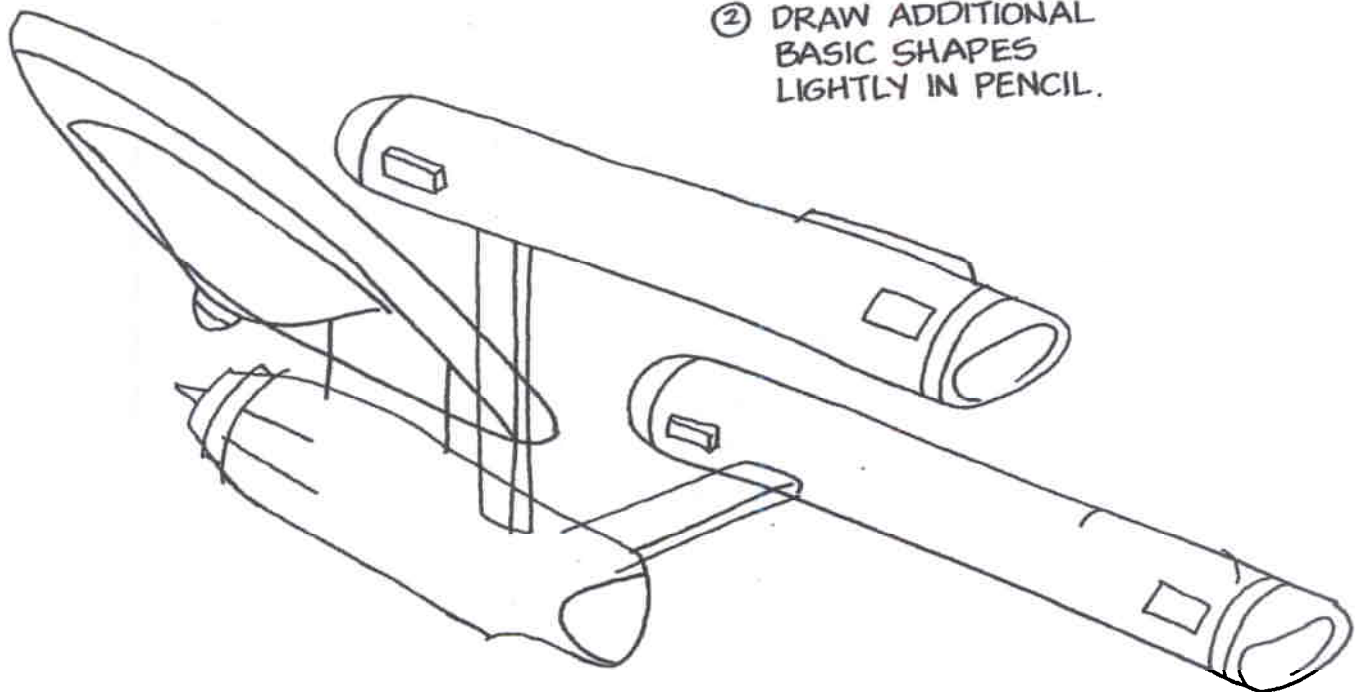

② DRAW ADDITIONAL
BASIC SHAPES
LIGHTLY IN PENCIL.

③ COMPLETE THE BASIC SHAPES USING A FINE-LINE MARKER AND ERASE THE PENCIL GUIDELINES.

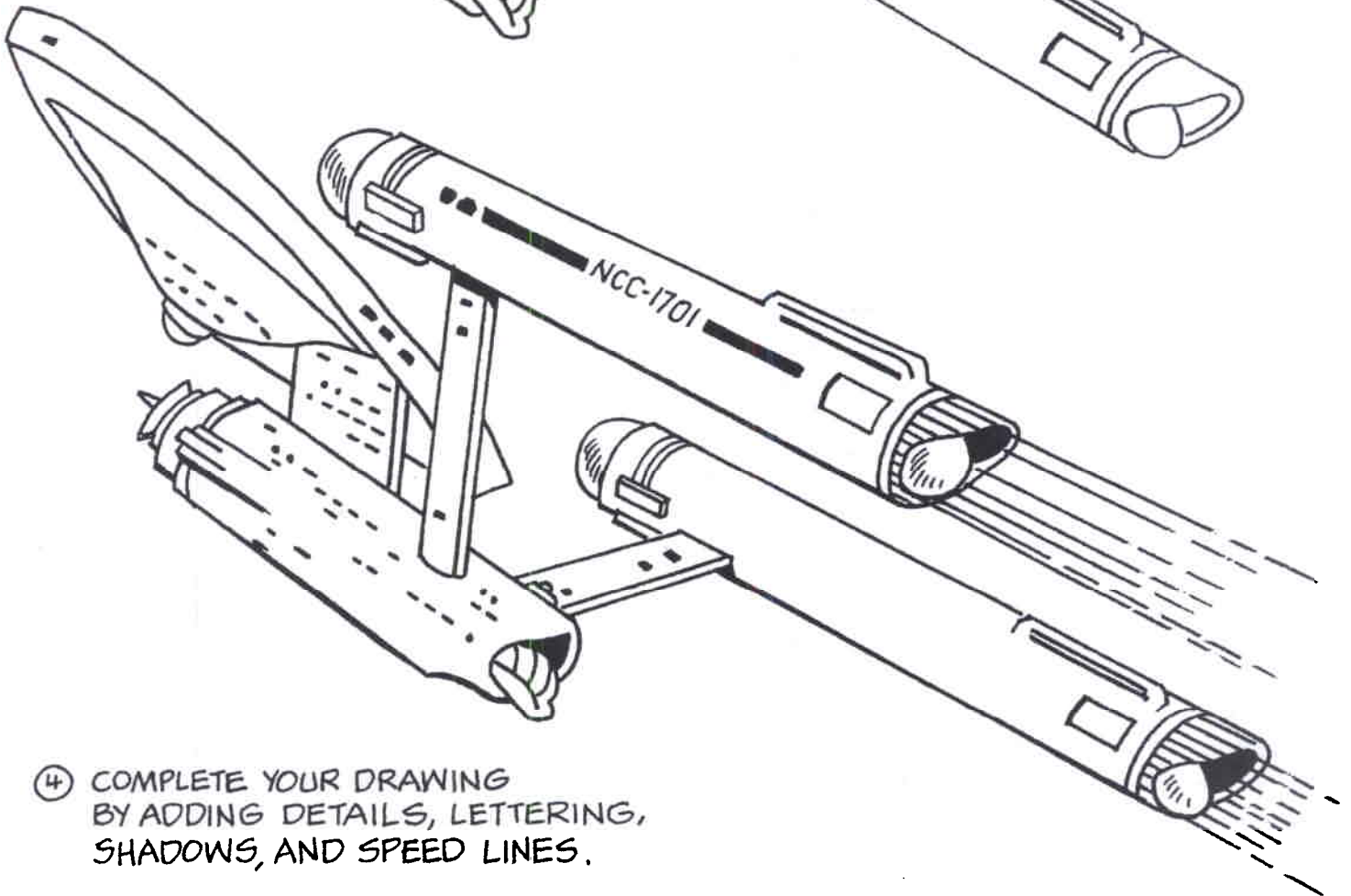
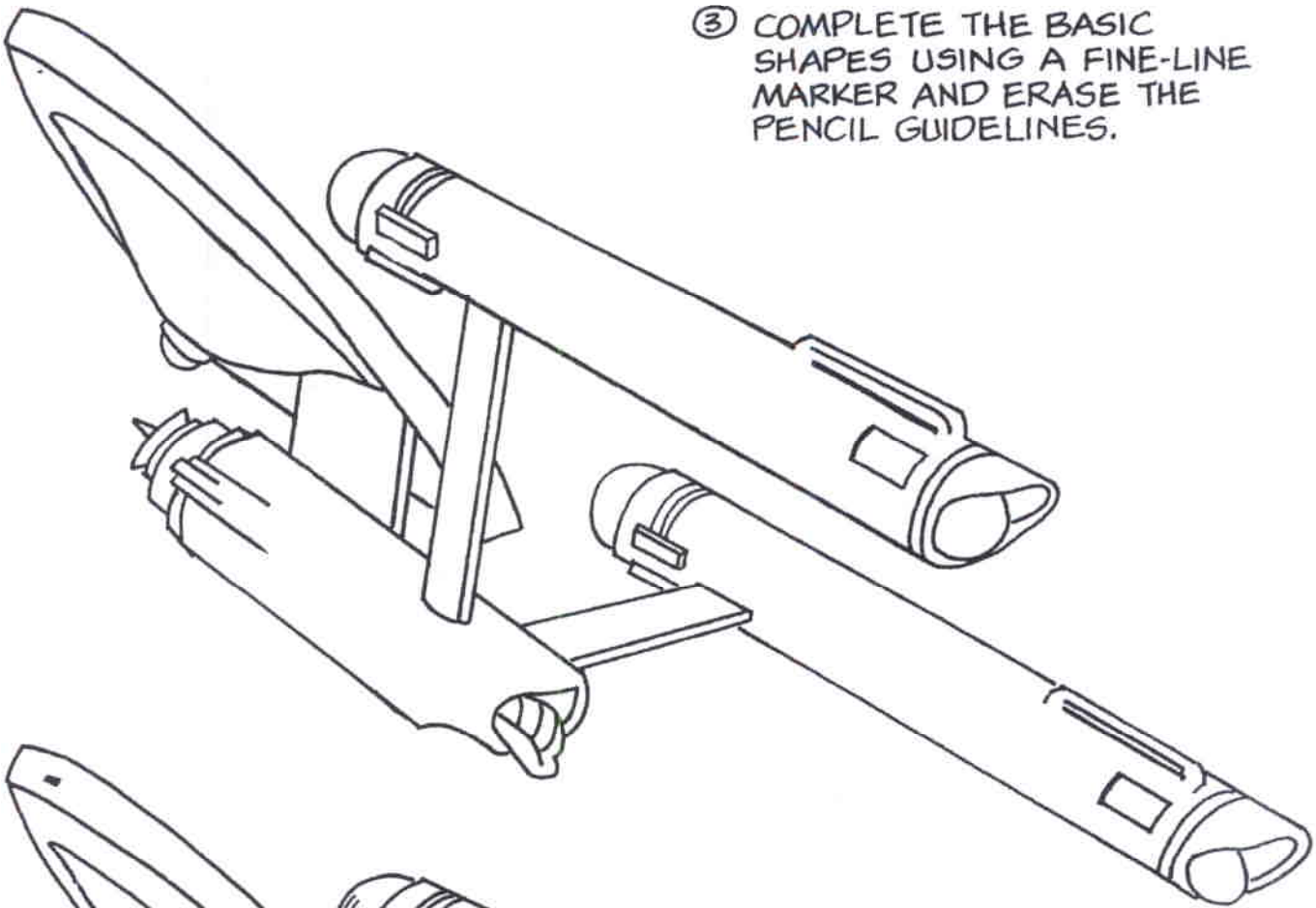

④ COMPLETE YOUR DRAWING BY ADDING DETAILS, LETTERING, SHADOWS, AND SPEED LINES.

35 Years of Star Trek

By George & Jill Bogler

On September 6-9, 2001 Slanted Fedora Entertainment held a convention in Las Vegas celebrating the 35th Anniversary of Star Trek. We were there, along with eight thousand others from 17 different countries. The guests alone numbered 72. (see more details at www.startrek.com).

The Convention really started on the 5th with pre-check-in. Although we had purchased our tickets a year ahead of time we still had to pick up our passes & other materials. They opened up at Noon for people to do this. To our surprise, when we got there at 1 pm, the line was snaked through the lobby, out the door, and down the sidewalk. Fortunately the hotel was not on the strip! It would eventually take us 5 hours to complete the line, and when we left it was still as long as when we arrived.

After getting our stuff, we went back to our hotel (around the corner from the con), changed clothes & went to Star Trek the Experience. That night only you were able to get your picture taken on the bridge! We ate at Quark's & Jill entered a costume contest with her Insurrection-style dress uniform. We both signed up for the trivia contest, but were not selected in the random drawing (We would've won, we would've!). They call their contest "Alien Squares". A Klingon, a Vulcan, and a Ferengi sit in booths and get asked trivia questions. The contestant agrees or disagrees with the answer. Although, to the best of our knowledge, they created their format independently, it closely resembles our own "Parrises Squares" concept!

Each day began with autograph sessions, then the actors appeared on stage singly or in groups of 2 or 3; then at the end of the day the designated cast appeared together. There were 2 stages, but the 2nd stage room got to see appearances on the main stage via closed circuit TV. Various evening events were available for extra cost. We decided to pass on those & "hotel hop" (or just recover!).

Thursday was the cast of The Next Generation plus William Shatner (Kirk) who had another convention to do Sat & Sun. He took questions, but lost his train of thought so often that he only answered three. Kate Mulgrew of Voyager appeared just after him and was delightful. There is a lot of Janeway in her, or vice versa. She is concentrating on her husband's career (He's running for Governor of Ohio) and will not be acting as much. She said, "I've had a great run, and I feel it's time to give something back". She was asked a lot of political & social questions, to which she gave very frank answers. Although the Voyager cast was not scheduled until Sunday, both Bob Picardo (EMH) and Garrett Wang (Harry Kim) came early. Garret came on stage for a brief moment while Kate was there, and ended up doing his Janeway impression. He does the entire cast except Roxanne.

After that appeared Brent Spiner (Data), Levar Burton (Geordi) and Gates McFadden (Beverly). There was a lot of teasing going on between these three. Brent is a natural stand-up comic and tended to "hog" the presentation. Levar talked a little about ENTERPRISE. He has directed one of the completed episodes and was to start another the Monday after the con.

Next came Marina Sirtis (Troi) and Michael Dorn (Worf). Somebody asked Michael about flying airplanes, and while he was answering Marina sort of rolled her eyes and asked the audience for a snack – low fat, low carb, etc. (she didn't actually get one, though). Apparently Michael is obsessed with airplanes & flying.

Marina stated that she became a U. S. Citizen just before the convention. She said it was interesting taking the oath because she was the only English-speaking person doing that. Michael compared working with the TNG cast to working with the DS9 cast. He stated that the TNG cast was light, upbeat & joking around while the DS9 cast was much more serious (according to the chant he did to describe it).

Also appearing this day was Wil Weaton (Wesley Crusher). He feels that Wesley was used as a tool to "save the day" in most of his episodes. Wil thinks Wes' potential was never fully or properly developed; and came to hate his character. That being the case, how can the viewers be blamed for hating Wesley as well? Wil currently heads a traveling improvisational comedy troupe.

Denise Crosby (Tasha) was supposed to be with the TNG crew this day, but had to switch with Rene Auberjonois. She later had to cancel all together due to an emergency situation on the set where she was working – the entire episode she was in was to be broadcast within a week & her entire scene had to be re-shot.

Friday was the cast of DS9. Avery Brooks (Sisko) & Colm Meaney (O'Brien) did not attend. Terry Farrell (Jadzia) was forced to cancel due to changes in her "Becker" Schedule. Rene Auberjonois (Odo) couldn't make Friday, but signed autographs on Thursday with the TNG cast. He only appeared on the 2nd stage & we missed that.

Because the autograph line was so huge, the promoters persuaded Lolita Fatjo (DS9 script editor), Max Grodenchek (Rom) and Aaron Eisenberg (Nog) to come on stage. They took a few questions, and Aaron mentioned that he had never been to a convention with Cirroc Lofton (Jake Sisko) before. That took up about ½ hour. Then the "real" programming of the day started. Cirroc Lofton came on first. He had just gotten back from a trip to Ethiopia, where his grandmother lives. He talked about his time on the show, and stated that for the first few shows, he never saw Aaron out of his Ferengi makeup, and so was constantly reacting to him as a kid. Aaron was 23 when DS9 started but, in his own words "was still immature". Then Aaron came up onstage as well. They talked about a juvenile "finger game" they used to play on the set, and made the comment that they pulled it on Nicole DeBoer (Ezri) when she first came on the set. She apparently stalked off, and they were afraid they had upset her, but when she got them back they relaxed. The audience persuaded Armin Shimmerman (Quark) to briefly bring his wife (Kitty Swank) up on stage. She was sitting with him in the autograph line signing her own photos. She played Keilana the female Vorta (and some other roles on DS9). Then Andrew Robinson (Garak) also came on stage. He is directing a play that Armin is in. Somebody asked Armin & Andy about the "tone on the set" (in reference to Michael Dorn's comments the day before). Armin stated that yes, the DS9 cast was serious about their work, and that it showed in the finished product. He asked the audience which show was better, and when the majority applauded DS9 he rested his case. Nicole DeBoer was fun. The host described her as "cute as a button" and that fits. She seems to have gotten the convention routine down though. Nana Visitor came on next for ½ hour and then Alexander Siddig for the last ½ hour. We didn't stay to hear them, as we had seen them in Salt Lake City. We went instead to the "little people" room for autographs of the supporting cast (see below). Finally, they brought out all the DS9 cast that was there out together. That was fun and was, as the promoter called it "a great geek moment".

Saturday, the date of the anniversary, was dedicated to The Original Series: Leonard Nimoy (Spock) spoke for a while, then the "Fab 4" Nichelle Nichols (Uhura), James Doohan (Scotty), George Takei (Sulu), and Walter Koenig (Chekov). At the end of the day Leonard came back, and was joined by Grace Lee Whitney (Rand) to complete the primary cast (except for Shatner, and of course DeForest Kelly).

All of these people are doing well & working on projects, with the exception of Jimmy. He uses a "scooter" to get around, tires easily, and finds it hard to speak. However you can tell that his mind and wit are still sharp. It is also clear that he loves doing the conventions. He had to take several breaks during the autograph session, but insisted on staying for everyone with an autograph ticket. Nichelle's project is writing the sequel to her book "Saturn's Child" called "Saturna's Quest". It should be out this fall.

Sunday they saved for Voyager. Jennifer Lein (Kes) appeared, but hardly spoke. Roxanne Dawson spoke on the irony of being pregnant for real during one season where they hid it on camera, and in character the next when she had to wear a pillow! She also has directed for ENTERPRISE & agrees with Levar that the fans are going to like the series. Everyone teased Robbie McNeil (Tom), who apparently is also "as cute as a button". Bob & Ethan did a very interesting impression of Jeri.

Access to the major stars was limited, due to the size of the convention as well as some security threats. When Jeri Ryan (7 of 9) came out, six guards surrounded the stage. We did not hear of any security problems that actually happened which was fortunate & none of the stars brought up the matter of any threats.

The other stars were in a second room where you could chat with them for a bit and get their autographs. Most of them were there all 4 days, but unfortunately the lines were often too big in there to do much with the more popular guests like Alice Krige (Borg Queen—1st Contact & Voyager Finale) & Allan Ruck (Captain Herriman of the Enterprise B). Aron Eisenberg (Nog) was taking photos of people in his line to put on his website (look for Jill). Robin Curtis (Saavik) and Mary Kay Adams (Grilka—"House of Quark"), and Lee Merriweather (Losira—"That which survives") were very gracious. Several one-shot guest stars were also there and willing to talk even if you didn't buy an autograph: France Nuyen (The Dolmann of Elas), Bobby Clark (The Gorn & misc redshirts), Michael Dante (Ma-ab, "Friday's Child"), Jack Donner (Sub Commander Tal—"The Enterprise Incident"), Gwenth Walsh & Barbara March (Lursa & B'Etor), plus real Astronauts, actors & stunt people from Battlestar Galactica, Babylon 5, Star Wars, 2001 A Space Odyssey & more. Many of these appeared on the 2nd stage as well.

Dave Scott, the host & head of Slanted Fedora Entertainment had everyone who came on stage sign the canvas stools they sat on & at the end of the Convention these were auctioned off for charity. The signings were a popular event after Kate Mulgrew turned away from the audience & bent over to sign hers.

Also at the end, Dave announced that Slanted Fedora had become a Paramount licensee; which means that he can offer future cons a lot more merchandise and other things. He is working with Paramount to get backstage tours of the sets to show (not sell) at conventions. He says that he has convinced them that fans want more & different things from conventions than have been available. Due to the success of this show, we would expect to see SF return to Las Vegas again.

QUOTE OF THE MONTH

"We can't be afraid of the wind."

Capt. Jonathan Archer

THUNDER CLASS MULTI-ENVIRONMENT INTERCEPTOR



Model by Andrew J. Hodges

Render by <http://www.geocities.com/romstar100>

U.S.S. Thunder NCC-13553

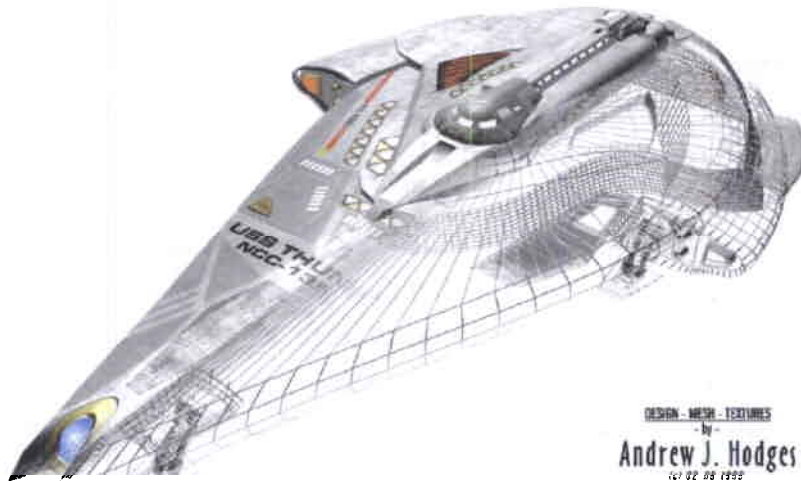

DESIGN - MESH - TEXTURES

by

Andrew J. Hodges

101 02 05 1999
starfleet2000@hotmail.com
ritualmembers@ad.com/~del_swar_d6

- Retractable Landing Gear
- Rapid Impulse-Assisted Ascent (RIAA)
- Integral Warp Nacelles
- Enhanced Impulse Fusion Propulsion
- Multi-Environment Capable (Class M, Demon Class, Underwater etc..)
- Dual-Mode Pulse/Stream Phasers
- Quantum/Photon Torpedo Launchers
- Multi-Spatial Regenerative Shields
- Ablative Hull Plating

Submitted By Adm. Dennis R. Hollinger

Engineering Goes Way Back

By Lt. Frank Buck, Assistant Chief Engineer

Engineering goes a lot farther back than we might realize. There have been circumstances when credit wasn't given for the efforts engineer's have made. For instance, the guys who built the Titanic tried to build an unsinkable ship, it sank (But they tried). Some of the guys who tried to build flying machines failed (But they tried). The Romans tried to rule the world by building the world's first roads, they failed (But they tried). These are only a few of history's hundreds of examples.

When I was 6 years old, my parents had so much trouble with me taking everything apart that they began giving me broken lawn mowers, chainsaws, and electrical tools that no longer worked in order to keep me away from the tools that did still work. At first all I could do was take them apart. I couldn't put them back together, (But I tried).

I remember the first time I took a broken chainsaw(chain not included) apart, then put it back together, and it worked!

The chainsaw was a blue with white letters Homelite Super XL-12 with a 16 inch bar and an automatic chain oiler. I think I was 8 years old. I was so happy with myself! My young age and inexperience were not the only obstacles I ever had to overcome to obtain success. I learned that with time and effort I was able to accomplish something that I set out to do.

When I was 12 years old I rebuilt my first engine, and yes, it ran when I was done! And although my confidence in my mechanical abilities was much higher, I was still just as thrilled when it fired and ran as I was when I put together the chainsaw at 8 years old..

When I was 14 years old I built my first vehicle from the ground up. It was a 1964 Chevy short bed stepside with a 283 and 4 speed transmission. It didn't look pretty, but I was so excited when I was able to get a licence and drive it (legally)! I still have that truck.

These are just some of my personal little mile stones. I really enjoy building stuff for the 7th Fleet. It makes me feel great when someone walks up and says "That looks cool! How did you make that?" I started out in the Security Department, but awhile back after looking at some of the stuff that I had made, Admiral Hollinger said something to me. He slapped me on the back and told me that I missed my calling. That got me thinking that as usual, he was right. I now realize I've been in Engineering my entire life in some way, shape, or form.

Over the years I've learned that success comes from not being afraid to try. If you look at some of your own experiences you'll see where your triumphs, be they large or small, have come from effort and determination, and you'll know that "you've tried"! Together we can make the 7th Fleet a mirror of the bright future that Star Trek exemplifies.

Our Favorite Characters

Spock is my favorite Star Trek character mainly because he is consistent. He is also stronger than humans. He has the ability to live for a long time and his amazing mental abilities.

Frank Buck

My all-time favorite Star Trek character is **Scotty**. I love many of the characters we have seen over the years--Quark, Janeway, Neelix, and others; but Scotty was one of my first heroes. I don't know why I didn't bond with Kirk or Spock. Perhaps they were too "large" for me to relate to. Scotty was a down to earth kind of guy who spent most of his time fixing Kirk's messes. Maybe it was the brogue. No problem was too big for Scotty. He would say it was, but once he got that out of his system, he buckled down and performed another miracle.

In later years Jimmy Doohan has become something of a personal hero outside of the role. I have attended several conventions featuring Jimmy and he has always been worth seeing. He has never let the popularity of Scotty go to his head. He always signs autographs for everyone in his line; although in recent years the line has needed to be limited. His talks have always been enjoyable & friendly.

George Bogler

I hate being asked who my favorite Star Trek character is because there are so many to choose from that it's hard to decide. So I'll have to say which is my favorite character **from** each series...

TOS: I believe my favorite character would have to be **Spock**. Spock is interesting because of the constant fight between his human and Vulcan halves. Yet most of the time this struggle is buried beneath the surface. We all face a similar dilemma when we struggle between our animal instincts and our intelligence.

TNG: Again, it's hard to decide. I'd probably have to say **Data**, for similar reasons to the above. Data's struggle toward humanity shows us what humanity really is.

DS9: My favorite DS9 character would have to be **Kira Nerys**. Kira speaks her mind (usually bluntly) and also is not afraid to state her religious views. She also shows us that, although hard to do sometimes, tolerance for another's beliefs is essential (see "Duet").

VOYAGER: **Janeway** has to be my favorite Voyager character. Here is a captain who, although she makes mistakes, always finds a way to set them right. Also, she's not afraid to carry a big gun when other methods fail.

ENTERPRISE: At the time of this submission, I have not yet seen the new show. From reading the article in TV Guide, it seems that the new show will have many exciting characters, and I look forward to viewing them regularly.

Jill Bogler

SESKA!!!! OF COURSE!!

As I have stated before I think Seska is such a good villain, she just makes people hate her. I wish to pay tribute to the ruthless and popular Cardassian. She is so bad! I just love her. I just love the way she is so evil. Even when she was disguised as a Bajoran she was naughty. She went and did everything wrong. Even to using the replicators to make wild mushroom soup for Chakotay. When she was caught trying to sell replicator technology to the Kazon-Nistram sect. She joined them and continued to be a thorn in Voyager's side. She even came back from the dead to give them trouble. Shortly before leaving the ship she discovered the existence of Insurrection Alpha, a holodeck training program. Seska rewrote the scenario to act as a trap to anyone who reopened the program's narrative parameters file. When it was opened by Tuvok and Tom Paris they were trapped in it until Captain Janeway was successful in rewriting portions of the scenario. In case you don't know about this watch Voyager's "Worse Case Scenario" again. It's a great show and she is a great villain!!!

Ruth Burns

A Trilling Experience

By Lt. Akiela Xal (a.k.a. Stephanie Thalmann)

Recently, Captain Henline asked members of the Kelly to respond to the question, "Who is your favorite Star Trek character, and why?" Is Kirk your favorite, because he is the ultimate space cowboy? Is Picard your favorite because of his European charm? What about Sisko and his shoot from the hip attitude? Or, who could forget Captain Janeway with her 'Starfleet' integrity, no matter how far away from home she may be?

Of course your favorite character does not have to be one of the Captains, it could be anyone ever mentioned on any episode of Star Trek. It could be Will Riker, with his brash good looks. Commander Chakotay and his rakish tattoo or Colonel Kira and her rebel attitude. Your favorite could be Mr. Spock or Mr. Tuvok because you are a Vulcan at heart. Or it could be Mr. Mott, Ensign Chell, or even Lindsey Ballard. What about Miramnee, Sarjenka, or Kai Opaka?

Everyone has their favorite character, and their own individual reasons for that personal choice. I have many different characters that I really enjoy watching. I enjoy both Montgomery Scott and Miles O'Brien with their Celtic charm and engineering skill. I've always been partial to the Doctors of Star Trek, whether it be Leonard McCoy, Beverly Crusher, Julian Bashir or "The Doctor." I wanted to join their club when I was growing up. Of course my favorite could be either Deanna Troi or Ezri Dax since they both studied the same thing as I did in college.

If you couldn't guess, though, my favorite character is actually Lt. Commander Jadzia Dax. She was not always my favorite, and I'm not really sure when or why she became my favorite. I remember a few years back, I had just purchased my DS9 uniform and wore it to work for Halloween. One of my co-workers asked me if I was "being Dax" for Halloween. I hadn't even thought about it at the time, but my co-worker said in that uniform with my hair in a ponytail I looked like a *distant* relative of hers. I took it as a bit of a complement, whether it was meant that way or not, and ever since then have done research on Jadzia Dax and everything Trill.

Of course, it's not much fun to have a favorite character who is dead. Her character will no longer grow, and it's just not the same with Ezri. Ezri is kind of fun though. Her fresh innocence is a change. Here we have a kid, not long out of the Academy who, with no preparation, now has a 400+ year-old symbiont inside of her. At least Jadzia was a little "world wise," but Ezri is still wet behind the ears. It's fun to watch her attempt to deal with the new experience of being joined.

Can you imagine being joined? Try as I might, I don't even come close. Do the mind of host and symbiont truly mesh, or do they maintain some individuality. I know that each Dax is different, because it takes on personality traits of the new hosts while maintaining some of the old characteristics. Can the host and the symbiont carry on a conversation? What would that be like? "Oh, how are you this morning, Dax?" "Fine Ezri, and you?"

I guess another main reason we choose our particular favorites is that they embody character traits that we admire. Maybe you wish you could shape-shift like Odo, or that you could fly like Tom Paris. I know that I wish that I were as calm under fire as Jadzia Dax. The character persona that I have created for myself has all the best Trill qualities plus a few extra. Until next time, "Keep on Trekkin."

COMMANDER WILLIAM THOMAS RIKER:

Will Riker is my favorite Star Trek character. He is resourceful, intelligent, loyal, honest and passionate in all phases of his life. He has had his chance to command other ships, but he prefers to remain on the Enterprise with Captain Picard. He is not afraid of command however, and according to Data, usually depends on unorthodox strategies in his command style. I like the way he used Worf's Klingon guile and Wesley's bit of anti-matter to defeat Picard in war games in the episode "Peak Performance." He will also do whatever it takes to accomplish his assignments...whether it be to seduce some alien woman, or order the death of his captain, or perhaps, just get down and kick some butt! I never got tired of seeing the next thing he would come up with. I wish I were more like him.

--Captain Richard Henline

As the Commanding Officer of a starship, and now with The Seventh Fleet, I have often turned to the leaders in Star Trek for inspiration. As I struggled with the question "Who is my favorite Star Trek character?", I did so again. I found a person who got the Borg to ask for help ("Scorpion"). A person who is not afraid to take off the jacket, pick up a phaser rifle and defend the ship ("Macrocism"). A person who is brave enough to make a friend ("The Void", "In the Flesh"), smart enough to out think the "Think Tank" and clever enough to out wit the Devore ("Counterpoint"). A person who is determined to win the fight ("Year of Hell", "The Killing Game") and can still be compassionate and understanding ("Good Shepherd"). A person who has gave her life for the crew ("Deadlock", "End Game"). My favorite character is **Captain Kathryn Janeway.**

--Admiral Dennis Hollinger



THE EAGLE CRIED

*HER HEART GRASPS FOR A REASON,
RENDERING TEARS SHE CANNOT HIDE.
HER TWIN NESTS KNOCKED DOWN TO THE GROUND,
WHILE HER CHILDREN WERE INSIDE*

*WITH GENEROUS HEART AND LOYAL WAYS,
SHE FINDS IT HARD TO UNDERSTAND,
A TERRIBLE ATTACK ON HER CHILDREN,
RESIDING IN THEIR OWN LAND.*

*HER BROKEN HEART WILL MEND, IN TIME,
LESS TIME WILL TAKE HER SHIELD.
JUSTICE WILL PREVAIL FOR HER,
FOR THAT SHE DOES NOT YIELD.*

*SPIRIT WRAPPED IN JUSTICE,
SHE WILL SPREAD HER MIGHTY WINGS,
SOAR HIGH ABOVE HER SACRED LAND,
WHERE LOVE AND FREEDOM RINGS.*

*WITH THREAT UPON THE NATION,
WHERE HER CHILDREN LIVED AND DIED,
OUR BELOVED EAGLE RAISED HER HEAD
IN SORROW....AND SHE CRIED.*

EAGLE ARTIST VERN TIDMORE

POEM BY RICKY KENDALL

THE POLITICS OF FANDOM

FROM AN ARTICLE BY BJO TRIMBLE

REPHRASED BY COMMANDER RUTH J. BURNS

Engaging in politics is the only way to keep an organization functioning as a unit instead of a random collection of people who get together now and then. While some people are quick to deride fanish politics, what they often mean is that they don't get their own way.

Nobody likes being told what to do, but rules are necessary as a behavior guideline. An individual who never follows any rules should never join an organization of any kind. There must be rules for an organization to exist, especially with all the diverse personalities that are drawn to it. Club officers have enough trouble trying to keep a club functioning smoothly, even with members willing to follow at least some of the rules!

The "Catch 22" of belonging to a club, is rules, which requires some politicking, which in turn annoys club members who don't want rules but do want a functioning club. Idealists hope that a club can exist without politics, but it is too difficult to deal with outside factors. A hobby organization is seldom a paying proposition, so leaders work without fee. Most club leaders are well-meaning amateurs with little administrative experience, and most members never become leaders because it is much easier to nit-pick and complain about what the leadership is doing wrong.

Most clubs get three basic types for officers or those who work on club projects:

- 1- Willing workers for the greater good until they burn out and disappear. Many well-meaning folk think nothing will ever get done unless they do it personally. Unfortunately, they are often correct. Far too many members sit on their fat apathy, waiting for someone else to do the work. When the club runs out of these willing workers, it usually marks the end of the group. For the greater good, officers should delegate authority, so that they don't do all the work and find themselves "burned out." And all members should volunteer to help out. If you are not willing to work for it, you really don't deserve the benefits of a well-running club.
- 2- The manipulative politician wants power but no hard work. This kind hates to let go of any power and rarely delegate authority. When things don't get done, everyone else gets the blame. A club needs to be sure that several copies of essential materials are available to other members of the club instead of being in the hands of just one individual. This will negate the need to recreate it, in case of loss or if the one who holds it leaves the club.
- 3- Followers are the workbees of a club, but usually not self-starters. They follow both good and bad politicians, with little ability to judge the difference. Discerning the club members can prevent problems from developing in a club by getting involved in politics. Don't groan! Become a knowledgeable member. Don't follow just because your friend is leading. Learn about the club, how it runs, and then you'll become a good member.

Take good care of your officers. Before joining or becoming a naysayer, take a good look at how well your club is run. What are other clubs doing? Are they long-lasting? What are the officers like? Do these other clubs run smoothly? Compare your club to all these others. Take a close look at your own club and make a decision. What kind of club do you want to belong to?

Your officers have worked long and hard to provide an enjoyable club for you to belong to, but they seldom hear a good word about all they do. Remember to give them an "atta-boy" or a heartfelt "thank-you", once in a while—it will completely surprise them! And it will probably renew their resolve to work harder to make the club better. This really doesn't involve politics, just simple courtesy.

Here's my THANKS to the Command Staff. I'd like THEM to hear it from THE REST OF YOU!

WORD SEARCH - ACTORS

- Alexander Siddig
- Andrew G. Robinson
- Armin Shimerman
- Aron Eisenberg
- Avery Brooks
- Brent Spiner
- Chase Masterson
- Cirroc Lofton
- Colm Meaney
- David Warner
- DeForest Kelley
- Denise Crosby
- Dwight Schultz
- Ethan Phillips
- Garrett Wang
- Gates McFadden
- George Takei
- Grace Lee Whitney
- James Doohan
- Jeffrey Combs
- Jennifer Lien
- Jeri Ryan
- John DeLancie
- Jonathan Frakes
- Kate Mulgrew
- Levar Burton
- Leonard Nimoy
- Majel Barrett Roddenberry
- Marc Alaimo
- Mark Lenard
- Max Grodenchik
- Michael Dorn
- Michelle Forbes
- Marina Sirtis
- Nana Visitor
- Nichelle Nichols
- Nicole deBoer
- Patrick Stewart
- Rene Auberjonois
- Robert Beltran



- Robert Duncan McNeill
- Robert Picardo
- Rosalind Chao
- Roxann Biggs
- Terry Farrell

- Tim Russ
- Walter Koenig
- Whoopi Goldberg
- Wil Wheaton
- William Shatner

Be the First to spot the typo and earn two extra Leadership Points.

Birthdays

OCTOBER

04 Charlene Smith
22 Luann Holfeltz
29 Dawn Anderson

NOVEMBER

02 Sandi Craig
08 Dawn Urton
09 Dennis Hollinger
10 Rhonda Hollinger
13 Kristin Cagle
23 Charles Jaehn
29 Galen Anderson

DECEMBER

04 Dorothy Woods (1st Birth Anniversary)
05 Richard & Cindy Henline Anniversary
16 Billy Ray Criag (4)
19 Mike Lookinland
28 Jed Smith
28 Jo Brown



The Kelly Communique is a non-profit newsletter published as a means of communication between Star Trek fans. It does not intend to infringe upon any rights.

"Star Trek," "Star Trek: The Next Generation," "Star Trek: Voyager," "Star Trek: Enterprise," "Star Trek: Voyager," and "Enterprise" are registered trademarks of Paramount Pictures Corp.

All rights are reserved to the original work herein. Copying without permission of the individual author or publisher is prohibited.

The Kelly Communique welcomes articles, stories, and art from all crewmembers. Submissions for the Winter 2002 Edition are due

December 1

NO EXCEPTIONS

IMPORTANT DATES:

Oct 02 Avery Brooks' Birthday
Oct 06-7 LDS Conference
Oct 08 Columbus Day (Holiday)
Oct 09 Scott Bakula's Birthday (47)*
Oct 12 Sr. Staff Meeting
Oct 13 Corn Maze Activity W/ Ticonderoga
Oct 15 Mark Lenard's Birth Anniversary
Oct 27 Robert Picardo's Birthday
Oct 28 Daylight Savings Time Ends
Oct 31 Halloween
Nov 05 Armin Shimmerman's Birthday
Nov 06 Election Day
Nov 06 Star Trek TMP Director's Cut Release
Nov 09 Robert Duncan McNeill's Birthday
Nov 09 Senior Staff Meeting
Nov 11-12 Veterans' Day
Nov 12 Wallace Shawn's Birthday
Nov 13 Whoopie Goldberg's Birthday
Nov 17 Thanksgiving Point Dinosaur Activity
Nov 19 Robert Beltran's Birthday
Nov 19 Terry Farrell's Birthday
Nov 21 Alexander Siddig's Birthday
Nov 22 Thanksgiving Day
Nov 24 Denise Crosby's Birthday
Nov 24 Dwight Shultz's Birthday
Nov 25 Ricardo Montalban's Birthday
Dec 01 Communique Articles Due
Dec 03 Brian Bonsall's Birthday
Dec 09 Michael Dorn's Birthday
Dec 14 Senior Staff Party
Dec 15 Garrett Wang's Birthday
Dec 20 Nicole DeBoer's Birthday
Dec 25 Christmas
Dec 28 Nichelle Nichols' Birthday

* If anyone knows the birthdays of the other stars of ENTERPRISE, please let the Command Staff know.